

# PEUGEOT

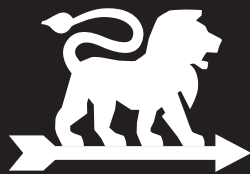

EnergySaw-600

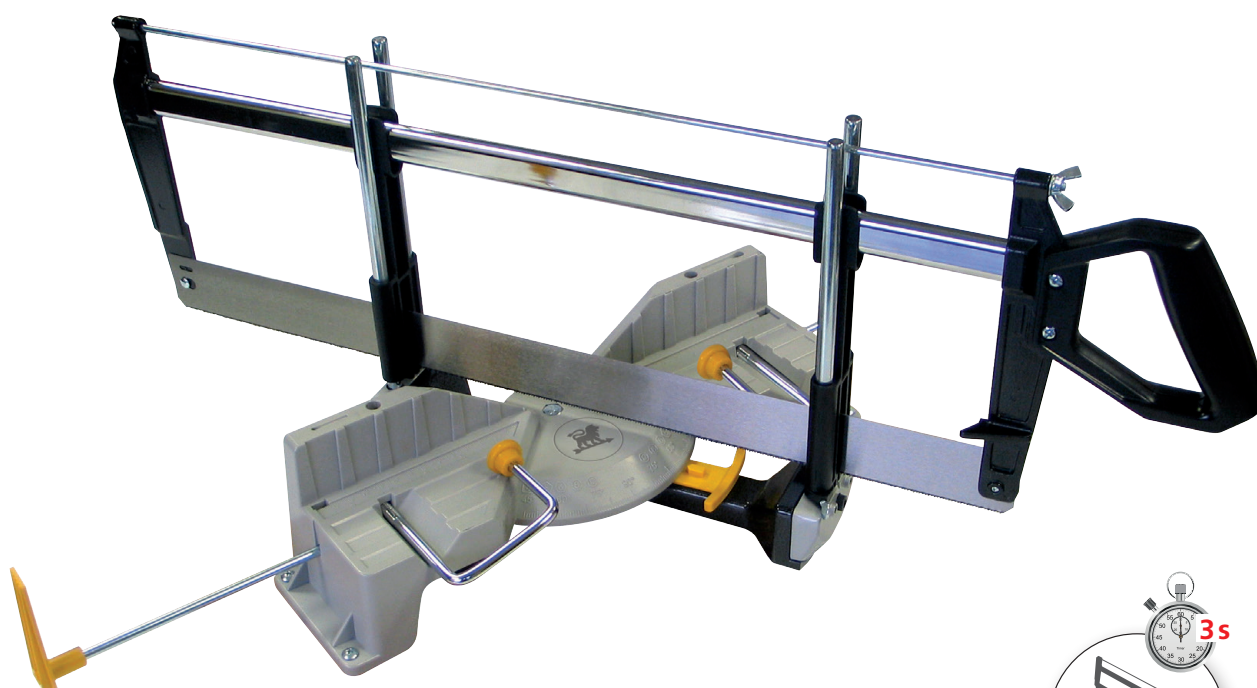

Peugeot Outillage

175041-3-Manual-C-20220401

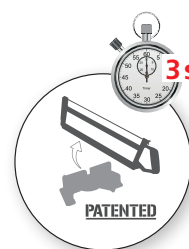

**FR** **MANUEL D'UTILISATION** (*Notice originale*) :  
**NL** **HANDBOEK** (*Vertaling van het oorspronkelijke*):  
**ES** **MANUAL** (*Traducción del original*):  
**PT** **MANUAL** (*Tradução do manual original*):  
**IT** **MANUAL** (*Traduzione dell'avvertenza originale*):  
**EN** **USING MANUAL** (*Original manual translation*):

**Scie à onglet manuelle**  
**Manual miter saw**  
**Sierra de inglete manual**  
**Troncatrice manuale**  
**Serra de esquadria manual**  
**Handmatig verstekzaag**

peugeot-outillage.com

175041

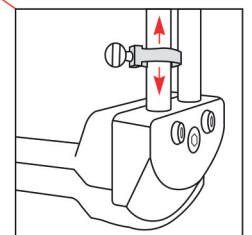
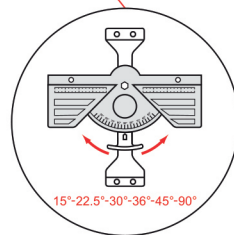
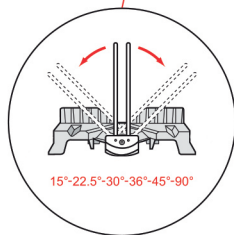
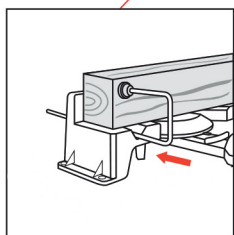
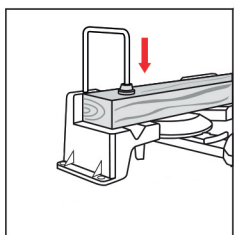
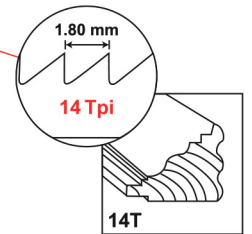
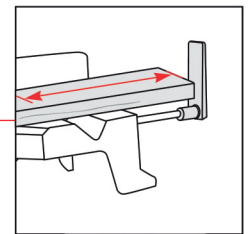
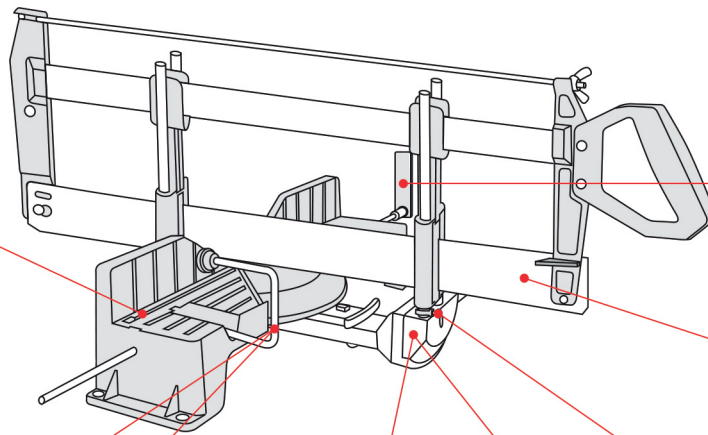
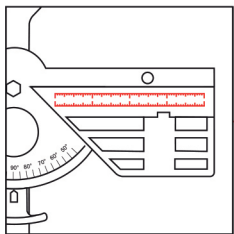
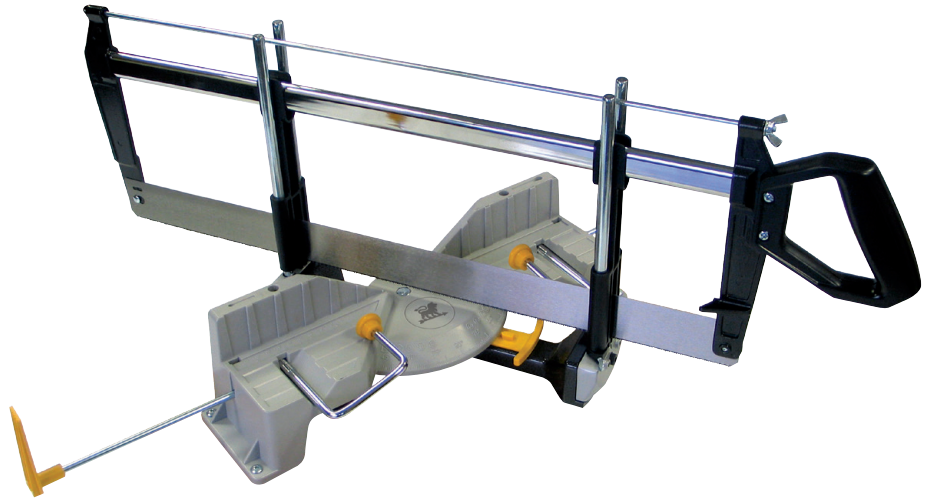
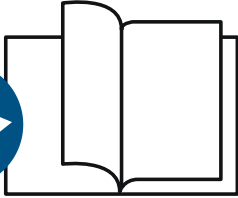
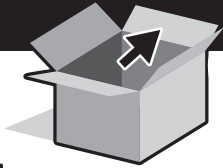

**FR COMMENT OBTENIR LA MEILLEURE COUPE**

1. La lame est suffisamment tendue pour éviter tout gauchissement susceptible de faire dévier la trajectoire.
2. La lame est «alignée» et centrée par rapport au châssis.
3. Après usage, détendez la lame.
4. La pièce à travailler est bien d'équerre et aux bonnes dimensions.
5. Vous utilisez le type de lame adapté au travail en cours.

**CARACTÉRISTIQUES FONCTIONNELLES**

1. Lame interchangeable.
2. Echelle pour lire rapidement la longueur.
3. Positionnement automatique sur les angles de coupe horizontales les plus courants : 6 butées positives pour la coupe en onglet à droite à 90°, 45°, 36°, 30°, 22,5° et 15°.
4. Etau de serrage.

**ES CÓMO OBTENER EL MEJOR CORTE**

1. La hoja está lo suficientemente apretada para evitar cualquier deformación que pueda hacer que el camino se desvíe.
2. La hoja está «alineada» y centrada con el marco.
3. Después de su uso, relaje la hoja.
4. La pieza de trabajo es cuadrada y de las dimensiones correctas.
5. Está utilizando el tipo de hoja correcto para el trabajo en cuestión.

**CARACTERÍSTICAS FUNCIONALES**

1. Cuchilla intercambiable.
2. Escala para leer rápidamente la longitud.
3. Posicionamiento automático en los ángulos de corte horizontales más habituales: 6 topes positivos para corte a inglete derecho a 90°, 45°, 36°, 30°, 22,5° y 15°.
4. Mordaza de sujeción.

**IT COME OTTENERE IL TAGLIO MIGLIORE**

1. La lama è sufficientemente stretta da evitare qualsiasi deformazione che potrebbe causare la deviazione del percorso.
2. La lama è «allineata» e centrata sul telaio.
3. Dopo l'uso, rilassare la lama.
4. Il pezzo in lavorazione è quadrato e delle dimensioni corrette.
5. Stai utilizzando il tipo corretto di lama per il lavoro da svolgere.

**CARATTERISTICHE FUNZIONALI**

1. Lama intercambiabile.
2. Scala per leggere rapidamente la lunghezza.
3. Posizionamento automatico sugli angoli di taglio orizzontali più comuni: 6 arresti positivi per il taglio obliquo destro a 90°, 45°, 36°, 30°, 22,5° e 15°.
4. Morsa di serraggio.

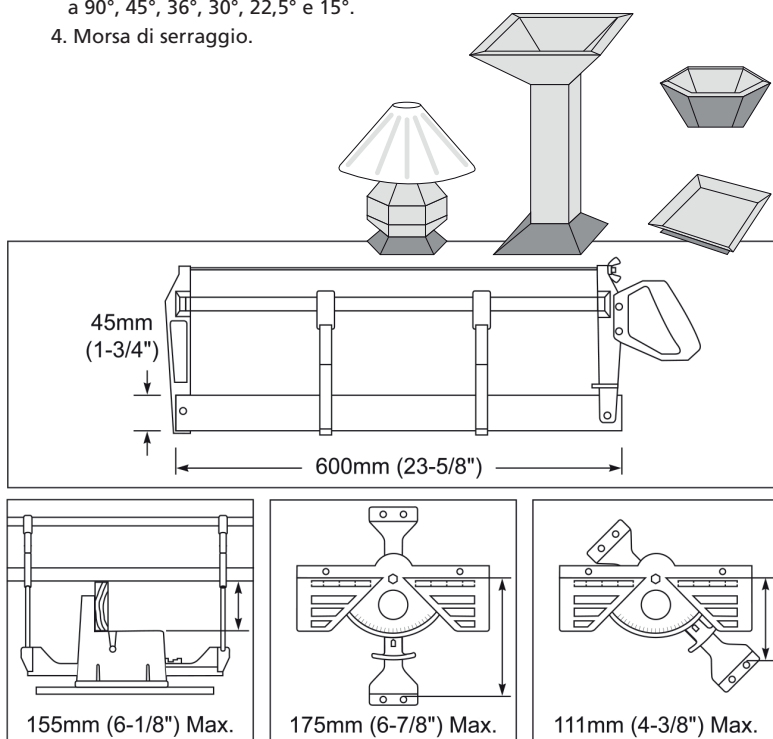
**NL HOE KRIJG JE DE BESTE SNIJ**

1. Het blad is strak genoeg om kromtrekken te voorkomen waardoor het pad zou kunnen afwijken.
2. Het blad is «uitgelijnd» en gecentreerd op het frame.
3. Na gebruik het mes ontspannen.
4. Het werkstuk is vierkant en heeft de juiste afmetingen.
5. U gebruikt het juiste type mes voor de uit te voeren klus.

**FUNCTIONELE KENMERKEN**

1. Verwisselbaar mes.
2. Schaal om snel de lengte af te lezen.
3. Automatische positionering op de meest voorkomende horizontale zaaghoeken: 6 positieve stops voor rechts verstek zagen op 90°, 45°, 36°, 30°, 22,5° en 15°.
4. Klembankschroef.

**PT COMO OBTER O MELHOR CORTE**

1. A lâmina está apertada o suficiente para evitar qualquer empenamento que possa fazer com que o caminho se desvie.
2. A lâmina está «alinhada» e centrada na estrutura.
3. Após o uso, relaxe a lâmina.
4. A peça de trabalho é quadrada e tem as dimensões corretas.
5. Você está usando o tipo correto de lâmina para o trabalho em questão.

**CARACTERÍSTICAS FUNCIONAIS**

1. Lâmina intercambiável.
2. Escala para ler rapidamente o comprimento.
3. Posicionamento automático nos ângulos de corte horizontais mais comuns: 6 paradas positivas para corte em esquadria direita a 90°, 45°, 36°, 30°, 22,5° e 15°.
4. Torno de fixação.

**EN HOW TO GET THE BEST CUT**

1. The blade is tight enough to avoid any warping that could cause the path to deviate.
2. The blade is «aligned» and centered to the frame.
3. After use, relax the blade.
4. The workpiece is square and of the correct dimensions.
5. You are using the correct type of blade for the job at hand.

**FUNCTIONAL CHARACTERISTICS**

1. Interchangeable blade.
2. Scale to quickly read the length.
3. Automatic positioning on the most common horizontal cutting angles: 6 positive stops for right miter cutting at 90°, 45°, 36°, 30°, 22.5° and 15°.
4. Clamping vice.

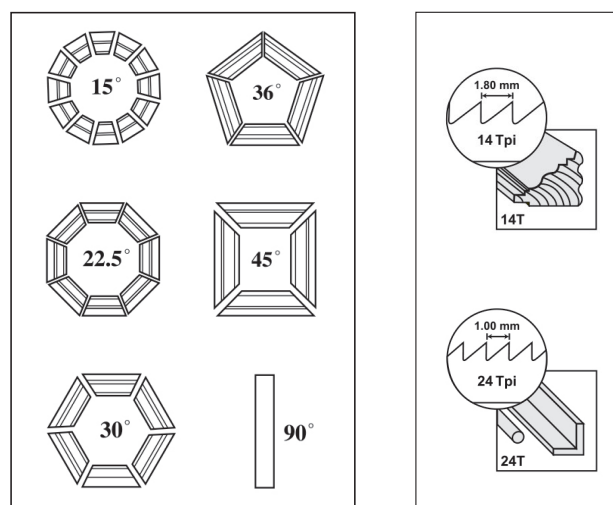

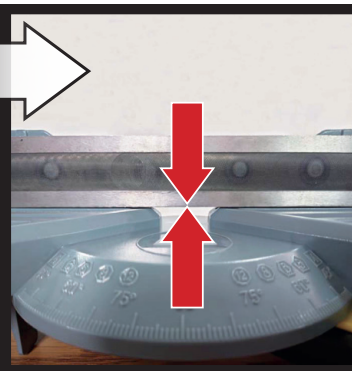
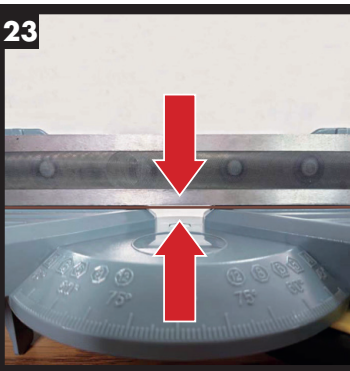
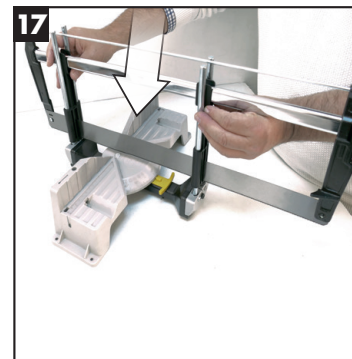
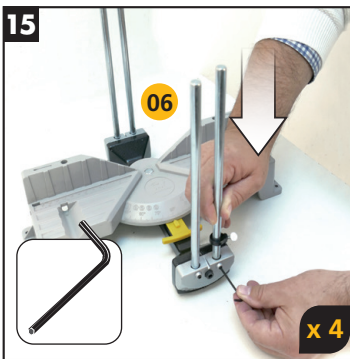
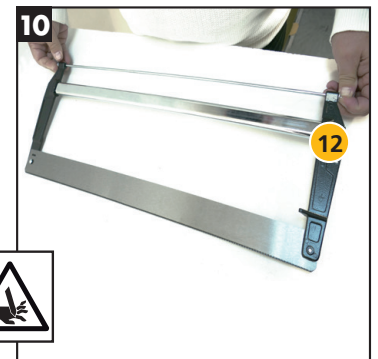
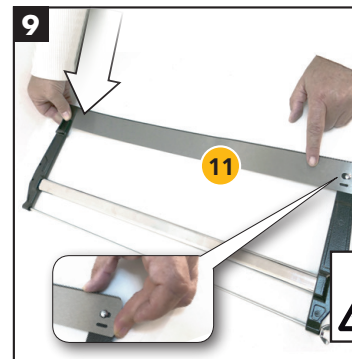
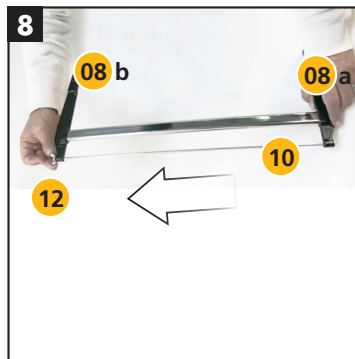
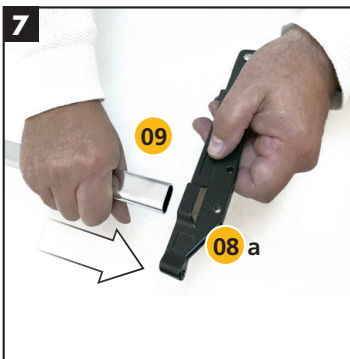
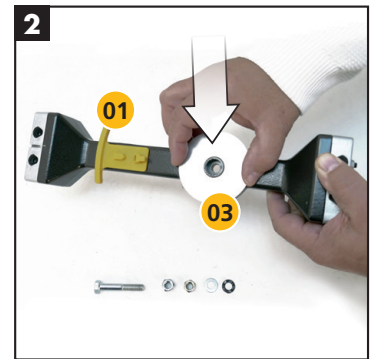
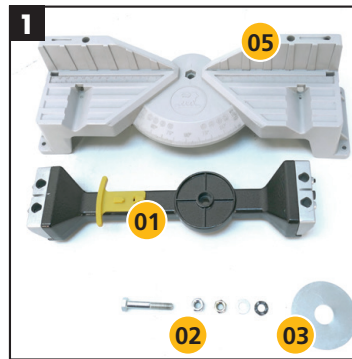
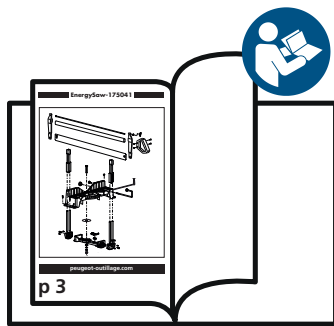
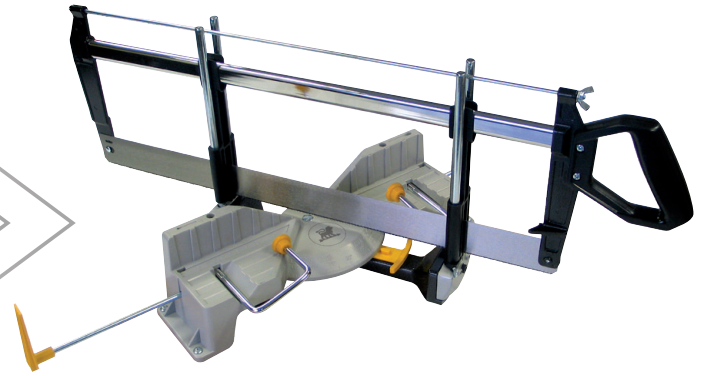
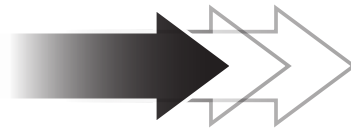

MERCI !



En consacrant seulement quelques minutes au montage de votre scie à onglet manuelle **PEUGEOT** vous permettez d'en diminuer l'impact environnemental !

Livrer cet outil non-monté permet une réduction de 53 % du volume de son emballage, et abaisse ainsi ses émissions de gaz à effet de serre :

- il utilise moins de ressources naturelles,
- son volume transporté est nettement plus faible.

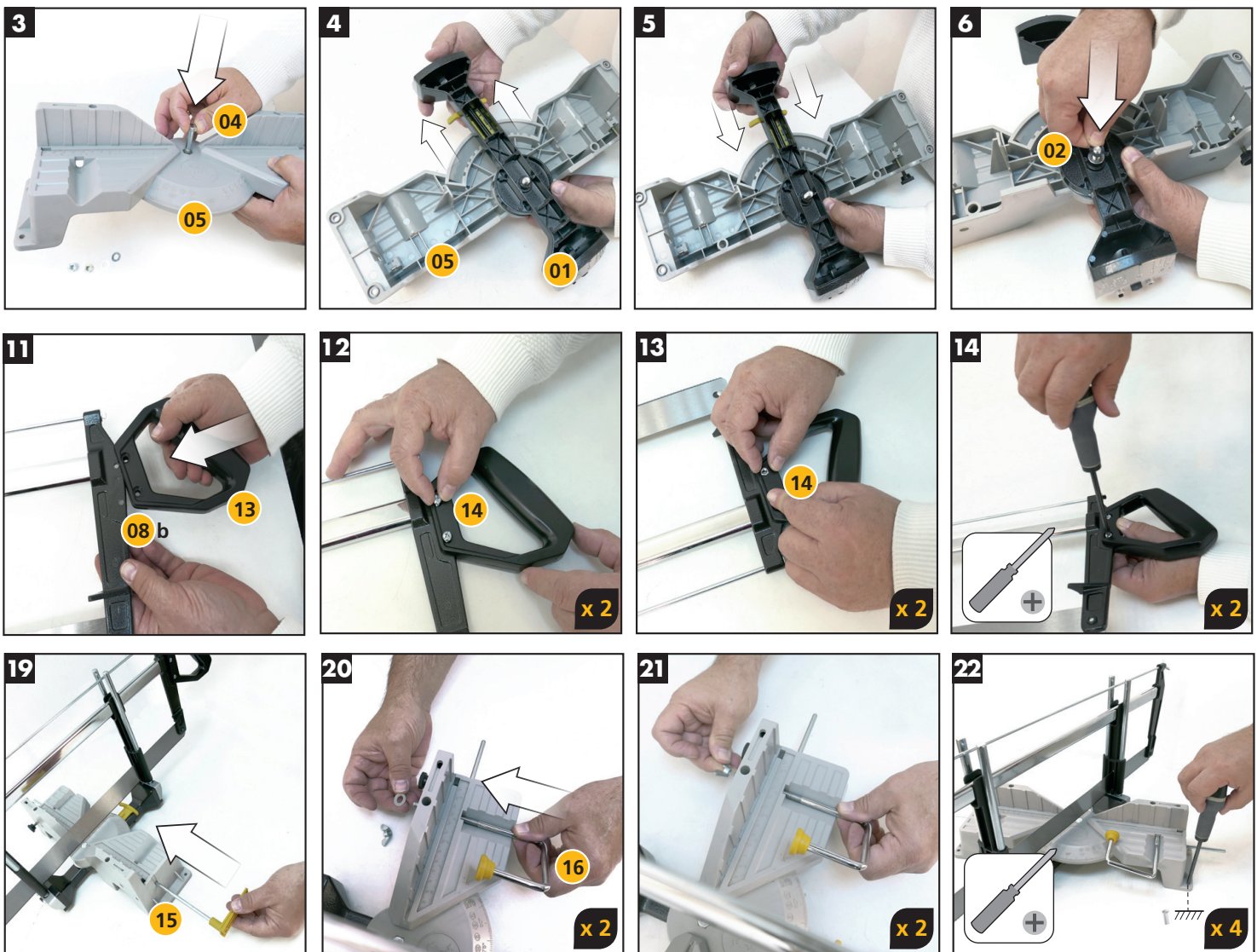

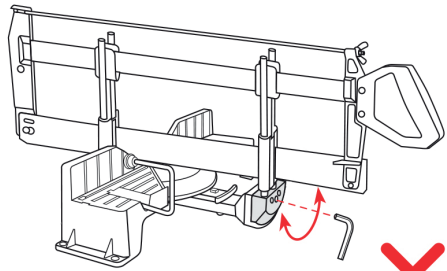

X

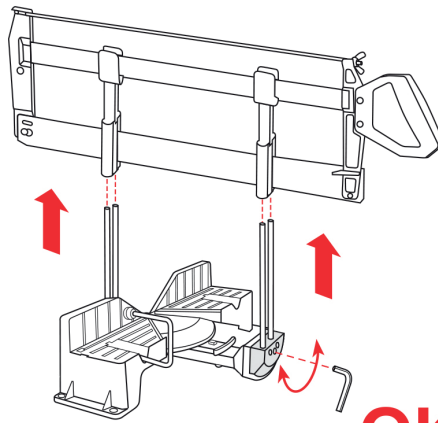

OK

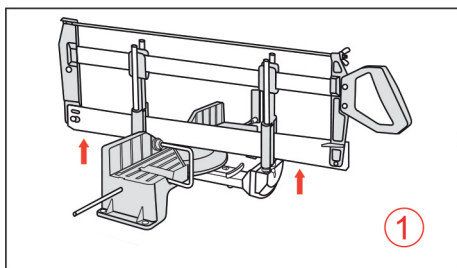
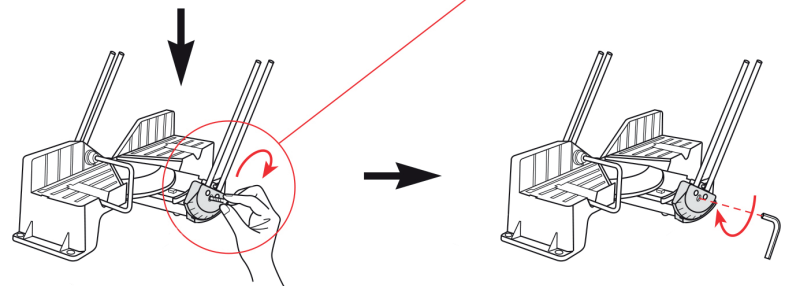
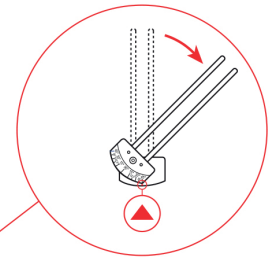
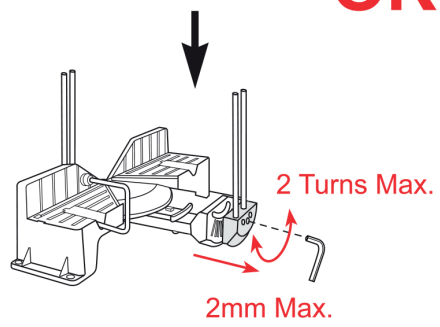
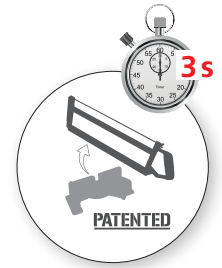

1

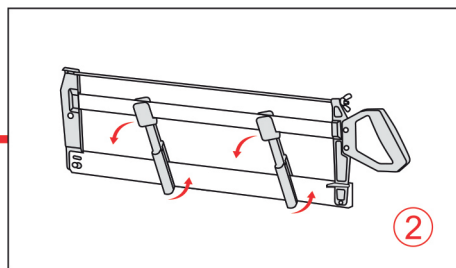

2

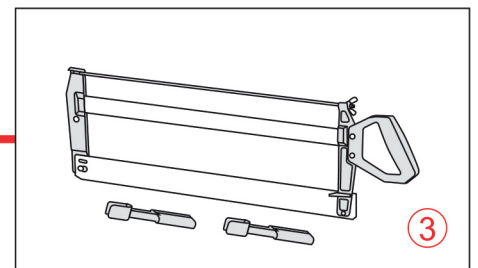

3





# PEUGEOT

## BON DE GARANTIE

**1 - Objet de la garantie :**  
La garantie porte exclusivement sur les vices de fabrication ou les vices de matières.  
Elle nous oblige à l'échange ou à la réparation des pièces reconnues hors d'usage.

**2 - Durée de la garantie :**  
La garantie est de 60 mois à dater de la livraison du matériel à l'utilisateur (facture ou ticket de caisse à fournir).  
Les échanges ou réparations faites au titre de la garantie ne peuvent avoir pour effet de prolonger celle-ci.  
Les frais de port ALLER sont à la charge de l'utilisateur.

**3 - Réserves :**  
La garantie ne s'applique en aucun cas aux réparations effectuées en dehors de nos réparateurs agréés.  
En aucun cas, durant la période de garantie, le matériel ne devra être démonté.

## GARANTIEKAART

**1 - Doel van de garantie:**  
De garantie heeft uitsluitend betrekking op fabricagefouten of gebreken in materialen.  
Het dwingt ons om uit te wisselen of reparatie van erkende onbruikbare onderdelen.

**2 - Duur van de garantie:**  
De garantie bedraagt 60 maanden vanaf de levering van apparatuur voor de gebruiker (factuur of kassabon te verstrekken).  
De uitwisseling of reparaties onder garantie niet te verlengen.  
GO verzendkosten zijn voor rekening van de gebruiker.

**3 - Reserves:**  
De garantie geldt niet in alle reparaties die buiten onze goedgekeurd reparateurs.  
In ieder geval gedurende de garantie, moet het materiaal worden verwijderd.

## TARJETA DE GARANTÍA

**1 - Objeto de la garantía:**  
La garantía sólo se referirá a los defectos de fabricación o defectos en los materiales.  
Nos obliga a cambiar o reparación de las piezas fuera de servicio reconocido.

**2 - Duración de la garantía:**  
La garantía es de 60 meses a partir de la entrega de equipos para el usuario (factura o recibo que se den).  
Los intercambios o reparaciones bajo garantía no tendrá que prolongarse.  
GO gastos de envío correrán a cargo del usuario.

**3 - Reservas:**  
La garantía no se aplica en todas las reparaciones realizadas fuera de nuestros talleres de reparación autorizados.  
En cualquier caso, durante el período de garantía, el material debe ser removido.

## CARTÃO DE GARANTIA

**1 - Finalidade da garantia:**  
A garantia só relacionar com defeitos de fabricação ou defeitos em materiais.  
Ela nos obriga a troca ou reparo de peças inseríveis reconhecidos.

**2 - Duração da Garantia:**  
A garantia é de 60 meses a partir da entrega de equipamentos para o usuário (factura ou recibo a ser fornecido).  
Trocias ou reparos sob a garantia não terá que prorrogá-la.  
GO porte serão custeadas pelo usuário.

**3 - Reservas:**  
A garantia não se aplica a quaisquer reparos feitos fora das nossas oficinas aprovadas.  
Em qualquer caso, durante o período de garantia, o material deve ser removido.

## GARANZIA

**1 - Oggetto della garanzia:**  
La garanzia si riferisce esclusivamente alla difetti di fabbricazione o difetti nei materiali.  
Ci costringe a scambio o la riparazione di parti inutilizzabili riconosciuti.

**2 - Durata della garanzia:**  
La garanzia è di 60 mesi dalla consegna delle attrezzature per l'utente (fattura o ricevuta da fornire).  
Scambi o riparazioni in garanzia non sarà necessario prolungarla.  
GO spese di spedizione sono a carico dell'utente.

**3 - Riserve:**  
La garanzia non si applica in tutte le riparazioni effettuate al di fuori dei nostri riparatori autorizzati.  
In ogni caso, durante il periodo di garanzia, il materiale deve essere rimosso.

## WARRANTY

**1 - Scope of the warranty :**  
The warranty shall only apply to manufacturing defects or material defects.  
We are obliged to exchange or repair parts that are identified as being unusable

**2 - Lifetime warranty :**  
The warranty shall be valid for 60 months from the delivery date of the equipment to the user (invoice or till receipt must be provided).  
Exchanges or repairs carried out under the warranty shall not extend the original warranty period.  
The user shall be responsible for original shipping charges.

**3 - Reservations :**  
The warranty shall not under any circumstances cover repairs carried out by a non-authorized repairer.  
The equipment should not be dismantled under any circumstances during the warranty period.

DATE D'ACHAT	RÉFÉRENCE MACHINE	CACHET DU DISTRIBUTEUR
DATUM VAN AANKOOP	MACHINEREFERENTIE	DEALER STEMPEL
FECHA DE COMPRA	REFERENCIA DE LA MÁQUINA	COMERCIANTE DE SELLOS
DATA DA COMPRA	REFERÊNCIA DE MÁQUINA	SELO REVENDEDOR
DATA DI ACQUISTO	RIFERIMENTO MACCHINA	TIMBRO DEL RIVENDITORE
PURCHASE DATE	MACHINE CODE	DISTRIBUTOR'S STAMP

## SERVICE APRÈS VENTE - AFTER SALE SERVICE

PEUGEOT OUTILLAGE - 192, Avenue Yves Farge - 37700 St. Pierre-des-Corps - FRANCE - Tél. : 02 36 16 71 46 - Fax : 02 36 16 71 40

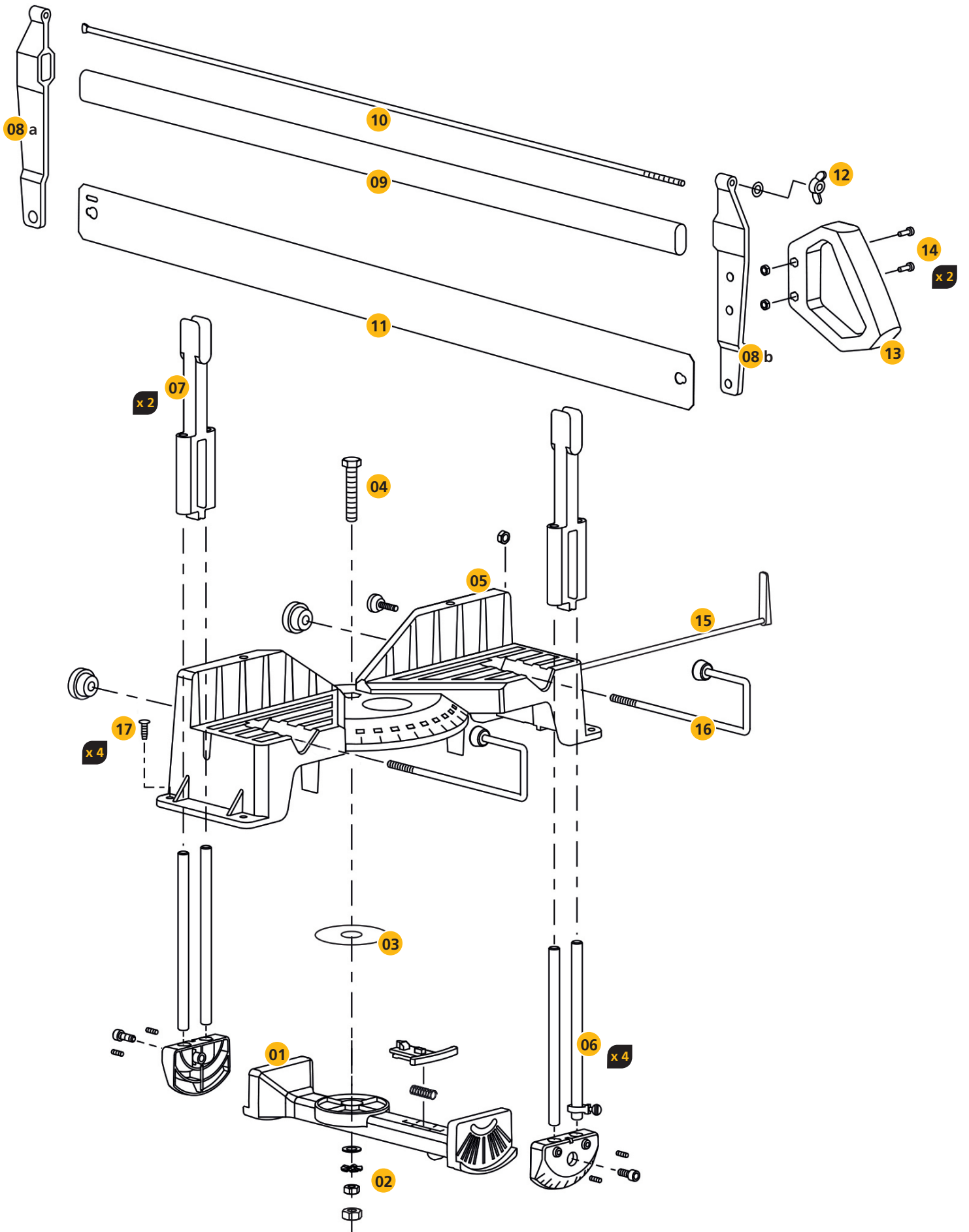







## PEUGEOT OUTILLAGE

Une société du groupe **SIGMA**

192, Avenue Yves Farge  
37700 St. Pierre-des-Corps  
FRANCE

[www.peugeot-outillage.com](http://www.peugeot-outillage.com)

