



EnergySaw-254SB



132033-4-G-20240212 Peugeot Outillage

FR MANUEL D'UTILISATION (Notice originale) :
NL HANDBOEK (Vertaling van het oorspronkelijke):
ES MANUAL (Traducción del original):
PT MANUAL (Tradução do manual original):
IT MANUAL (Traduzione dell'avvertenza originale):
EN USING MANUAL (Original manual translation):

Scie à onglets radiale
Radiaal verstekzaag
Sierra ingletadora radial
Serra a onglete radial
Troncatrice radiale
Sliding electric mitre saw

peugeot-outillage.com

FR

Une scie à onglet sert à réaliser simultanément ou non des coupes en angle et en biseau de manière précise sans risque de déviation de la lame - très utile pour les travaux d'encadrement, de décoration tels que pose de lambris et parquet.

Plus le nombre de dents est important, plus la coupe est fine.

La fonction radiale, si votre machine en est équipée, permet de couper des pièces plus larges par exemple lames de parquet, planches de coffrage, étagères...

Le laser, si votre machine en est équipée, permet de projeter un faisceau matérialisant le passage de l'outil.

Recherchez une machine dont les capacités de coupe conviennent aux travaux que vous souhaitez entreprendre.

EN

A mitre saw is used to make precise simultaneous angled and bevelled cuts, without any risk of the blade slipping - very useful for making picture frames and for decorative work such as wood panelling or flooring.

The more teeth the blade has, the finer the cut.

The radial function, if your machine has it, means that you can cut wider pieces, for example: parquet strips, shuttering boards, shelves, etc.

The laser, if your machine has one, produces a beam of light which shows you where the blade will go.

Look for a machine whose cutting capacities are suited to the kind of work you are doing.

ES

Una sierra de ingletes sirve para realizar simultáneamente o no cortes en ángulo y en bisel de forma precisa sin riesgo de desviación de la hoja - muy útil para la realización de marcos, los trabajos de decoración tales como la colocación de frisos y parquet.

Cuanto más importante es el número de dientes, más fino es el corte.

La función radial, si su máquina está equipada con esta función, permite cortar piezas más anchas, como por ejemplo: tablas de parquet, tablas para encofrados, estantes...

El láser, si su máquina está equipada con esta función, permite proyectar un haz que materializa el paso de la herramienta. Busque una máquina cuyas capacidades de corte sean convenientes para las obras que desea realizar.

IT

Una sega per tagli obliqui serve a realizzare simultaneamente o no dei tagli ad angoloe obliqui in modo preciso, senza rischio di deviazione della lama - molto utile per i lavori di incorniciatura, di decorazione come la posa di rivestimenti in legno e parquet.

Più il numero di denti è importante, più il taglio è perfetto.

La funzione radiale, se la vostra macchina ne ha una, permette di tagliare dei pezzi più larghi, per esempio: lame di parquet, tavole per armatura, mensole...

Il laser, se la vostra macchina ne ha uno, permette di proiettare un fascio che materializza il passaggio dell'attrezzo.

Cercare una macchina la cui capacità di taglio è adeguata ai lavori che si vogliono fare.

PT

Uma serra angular permite realizar, simultaneamente ou não, cortes em ângulo e em bisel de maneira precisa e sem riscos de desvio da lâmina - muito útil para a confecção de molduras e trabalhos de decoração, como a colocação de lambris e parquets.

Quanto maior é o número de dentes, mais fino é o corte.

A função radial, se a sua máquina possuir este recurso, permite cortar peças mais largas. Ex.: lâminas de parquet, placas de cofragem, prateleiras, etc.

O laser, se a sua máquina possuir, permite projectar um feixe que materializa a trajectória da ferramenta.

Opte por uma máquina cujas capacidades de corte convenham ao trabalho que deseja realizar.

**X4**

FIG. A & B





3
X2

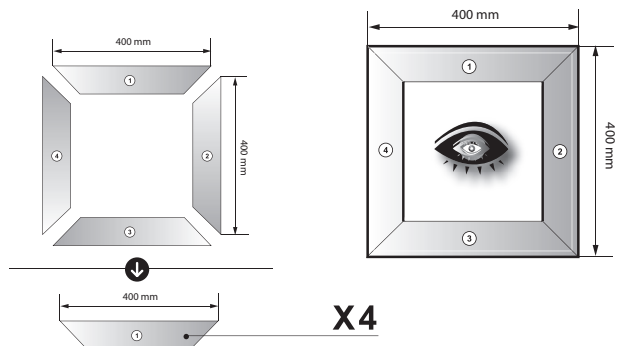
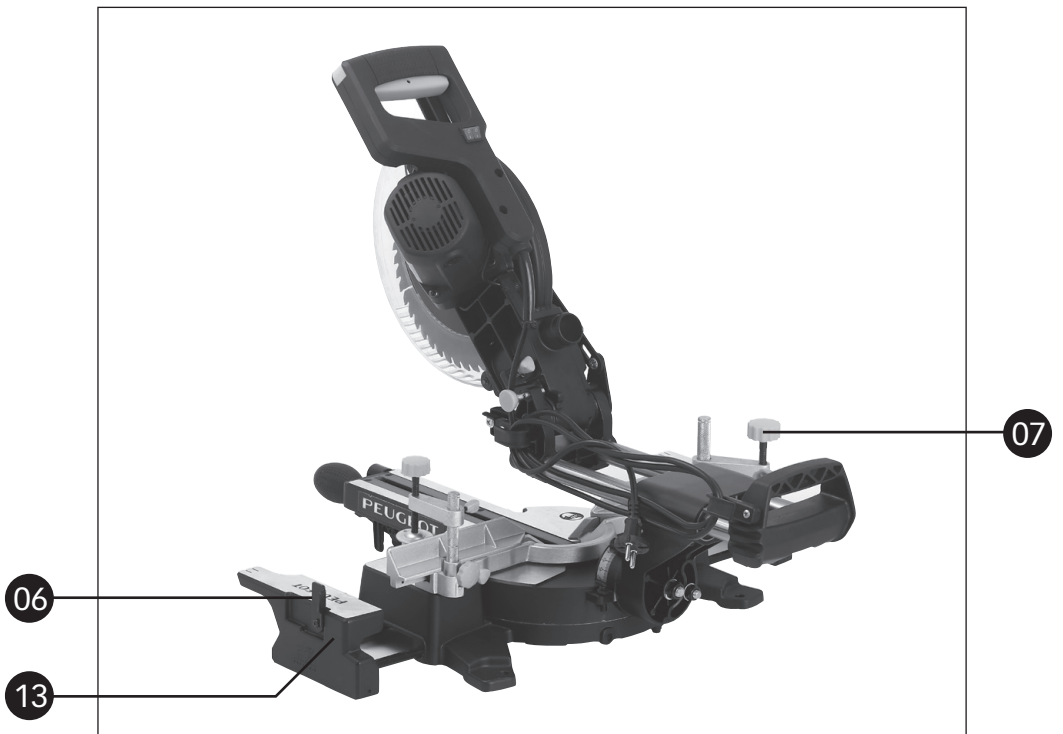
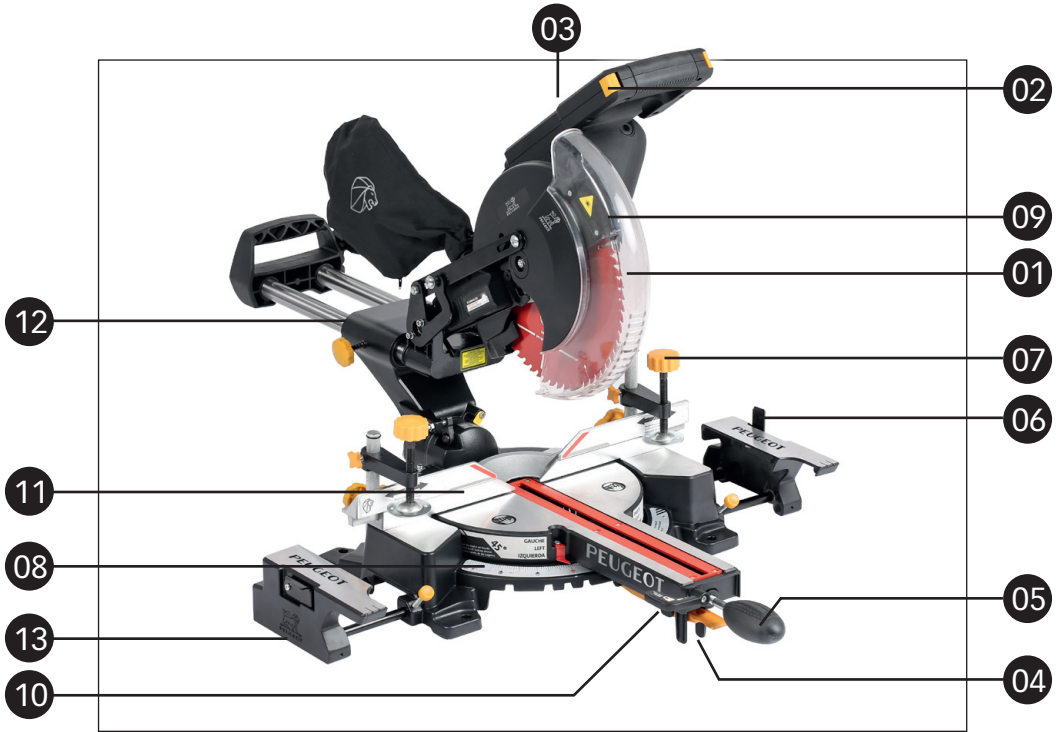

X2



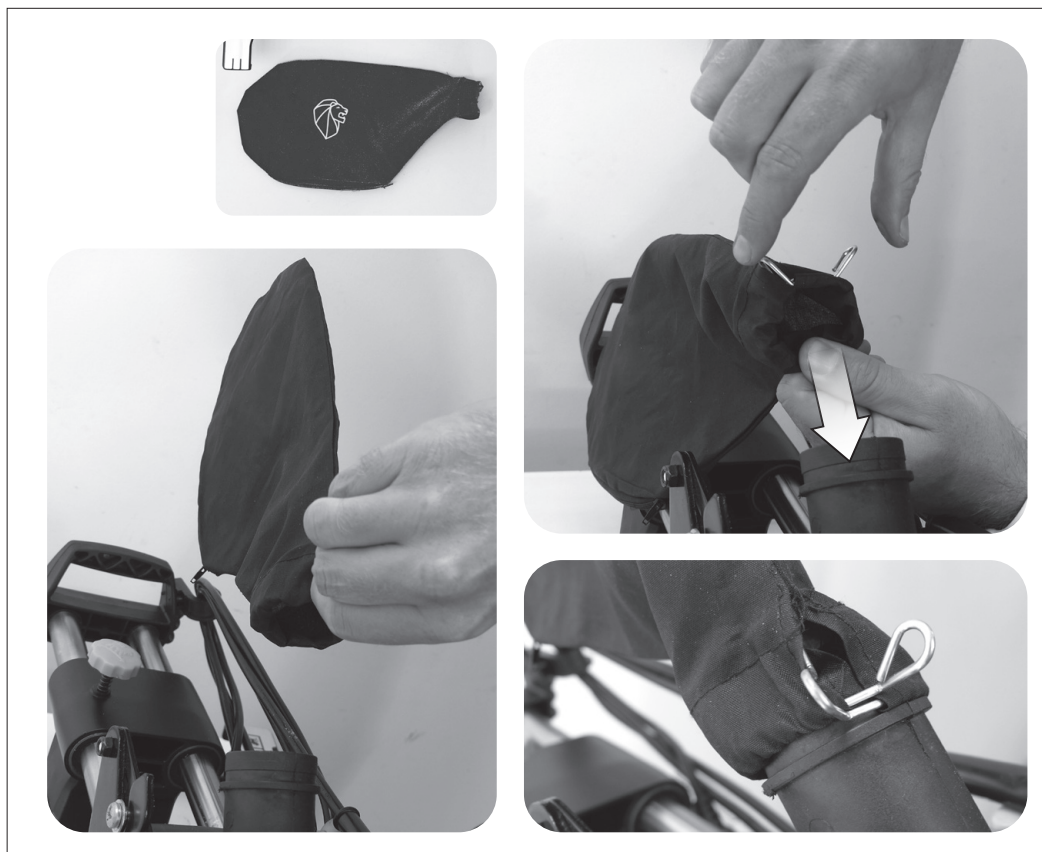

Montage des extensions de table

Montage van de tafel extensies
 El montaje de las extensiones de la mesa
 Montar as extensões de mesa
 Montaggio delle prolunghe
 Mounting the table extensions

Répéter l'opération pour l'autre côté

Herhaal dit voor de andere kant
 Repita para el otro lado
 Repita a operação para o outro lado
 Ripetere l'operazione per l'altro lato
 Repeat operation for the other side

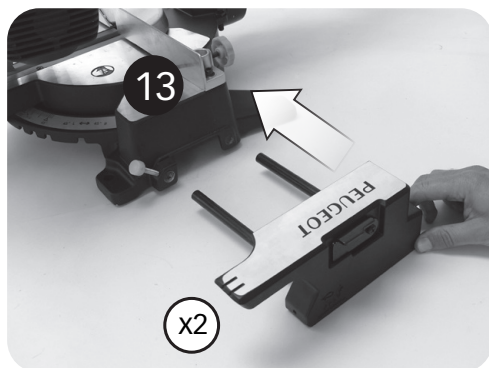

02

Vis de verrouillage des extensions

Borgschroef extensies
 Bloqueo de extensiones de tornillo
 Bloqueo extensões de parafuso
 Blocco estensioni a vite
 Extensions blocking screw

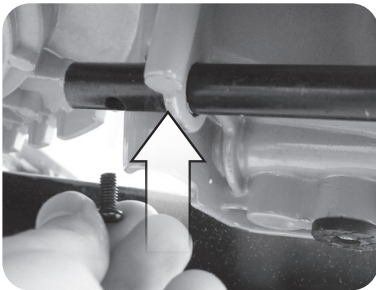
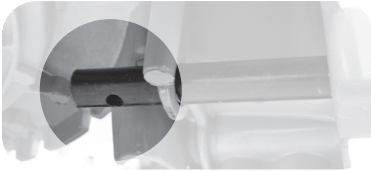

Répéter l'opération pour l'autre côté

Herhaal dit voor de andere kant
 Repita para el otro lado
 Repita a operação para o outro lado
 Ripetere l'operazione per l'altro lato
 Repeat operation for the other side

02

Sécurité anti-basculement

Anti-kantelmechanisme
 Antivuelco
 Mecanismo anti-tombamento
 Meccanismo anti-ribaltamento
 Anti-tipping mechanism



FIG. D

03

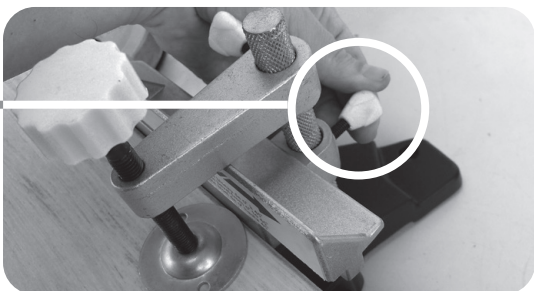
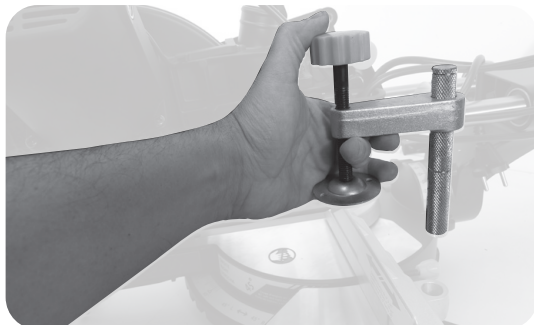

Verrouillage
 Vergrendelen
 Bloquear
 Trancar
 Bloccaggio
 Locking

FIG. E

01

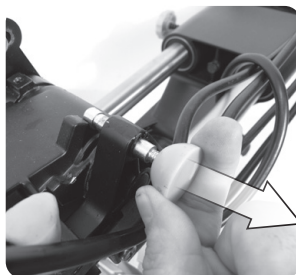
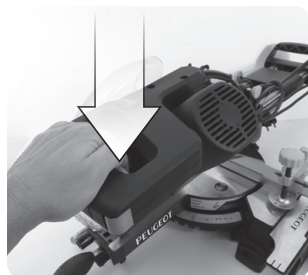

b



Tirer le loquet de déverrouillage
 Trek aan de ontgrendeling
 Tire del pestillo de liberación
 Puxe a trava de liberação
 Tirare il fermo di rilascio
 Pull the release latch

a

Appuyer sur la tête
 Druk op de kop
 Presionar la cabeza
 Pressione a cabeça
 Stampa il capo
 Press the head

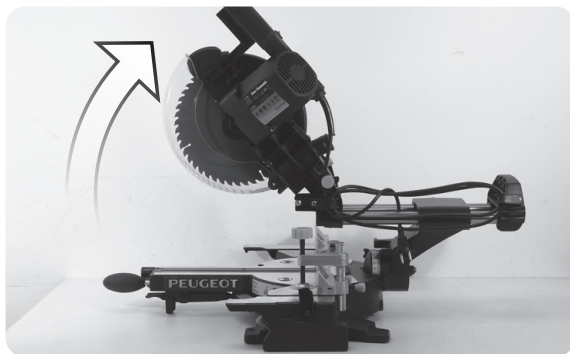

02

**Déverrouillage du plateau**

Ladevergrendeling
Bloqueo de bandeja
Bandeja de bloqueio
Blocco del vassoio
Unlock

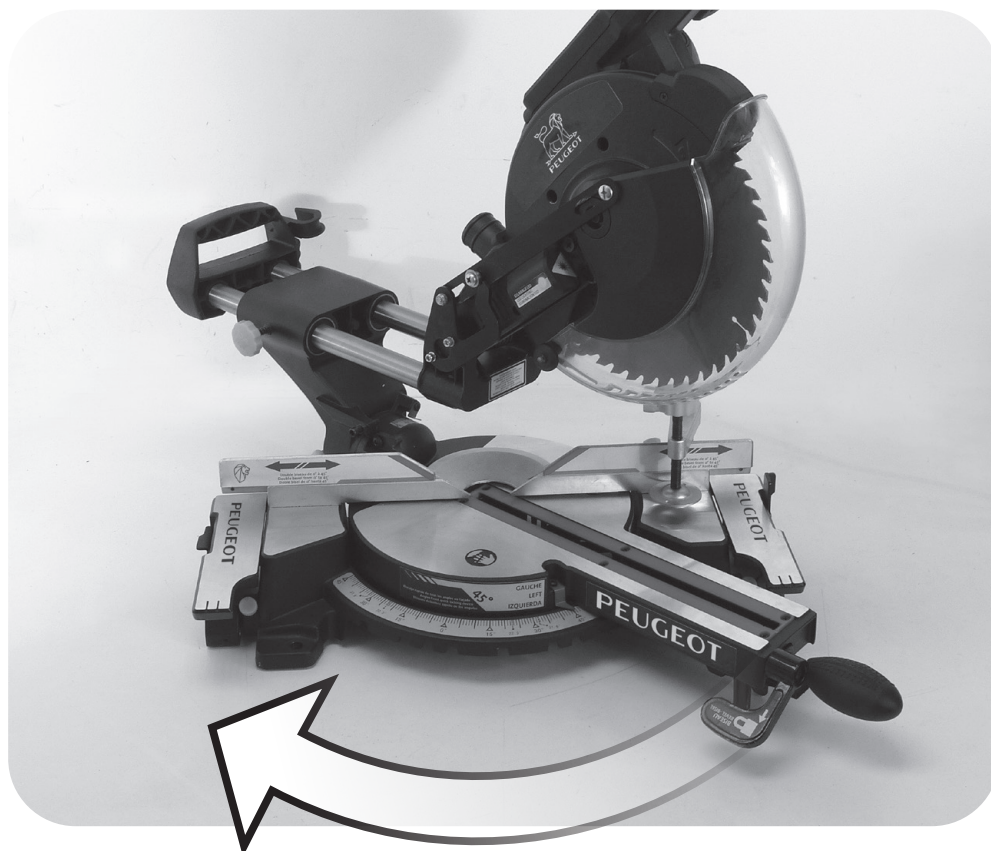
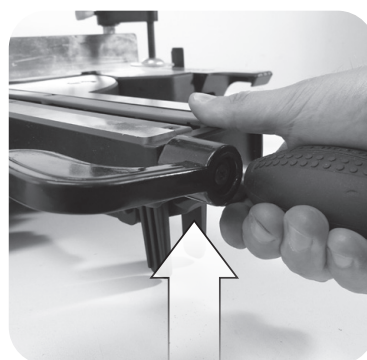
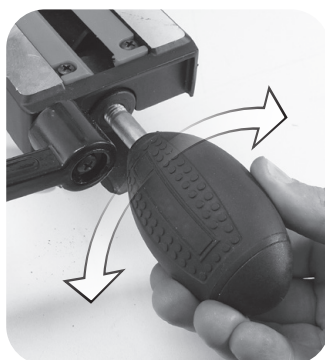

03

Inclinaison de la tête à gauche
 Head tilt links
 Inclinação de la cabeza hacia la izquierda
 A inclinação da cabeça para a esquerda
 Inclinare la testa a sinistra
 Head tilt left

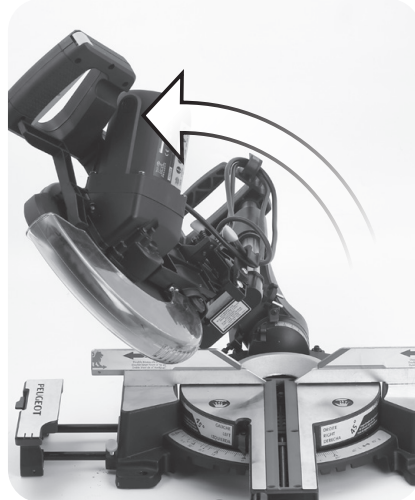
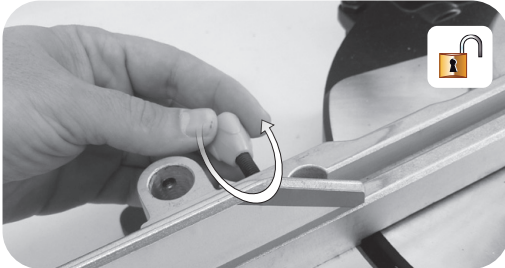
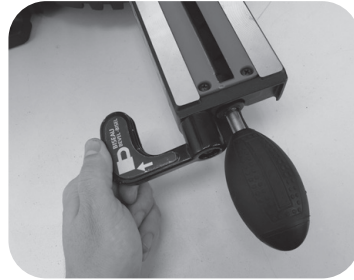
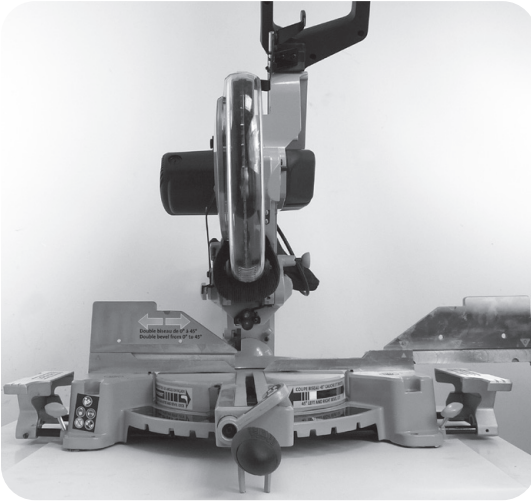

Inclinaison de la tête à droite
 Head tilt rechts
 Inclinación de la cabeza hacia derecha
 A inclinação da cabeça para a direita
 Inclinare la testa destra
 Head tilt right

03

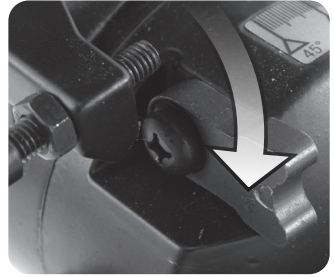
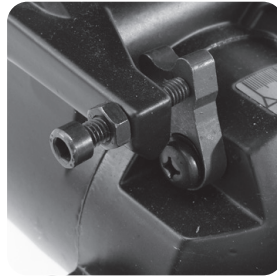
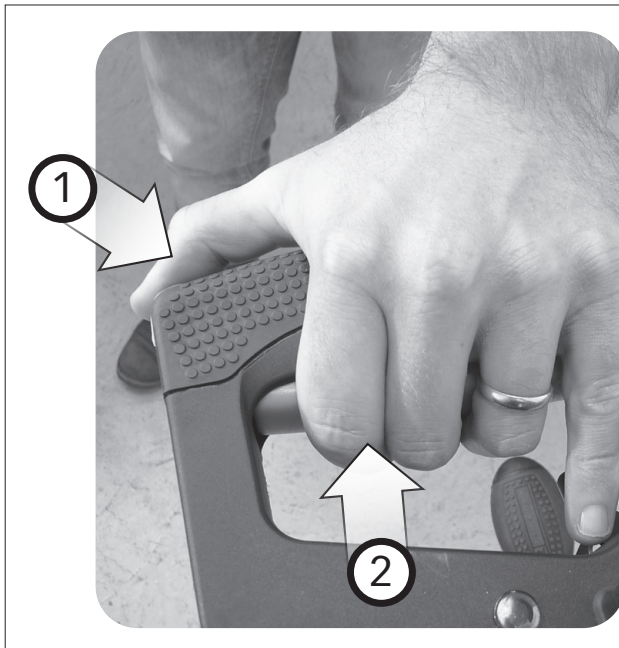
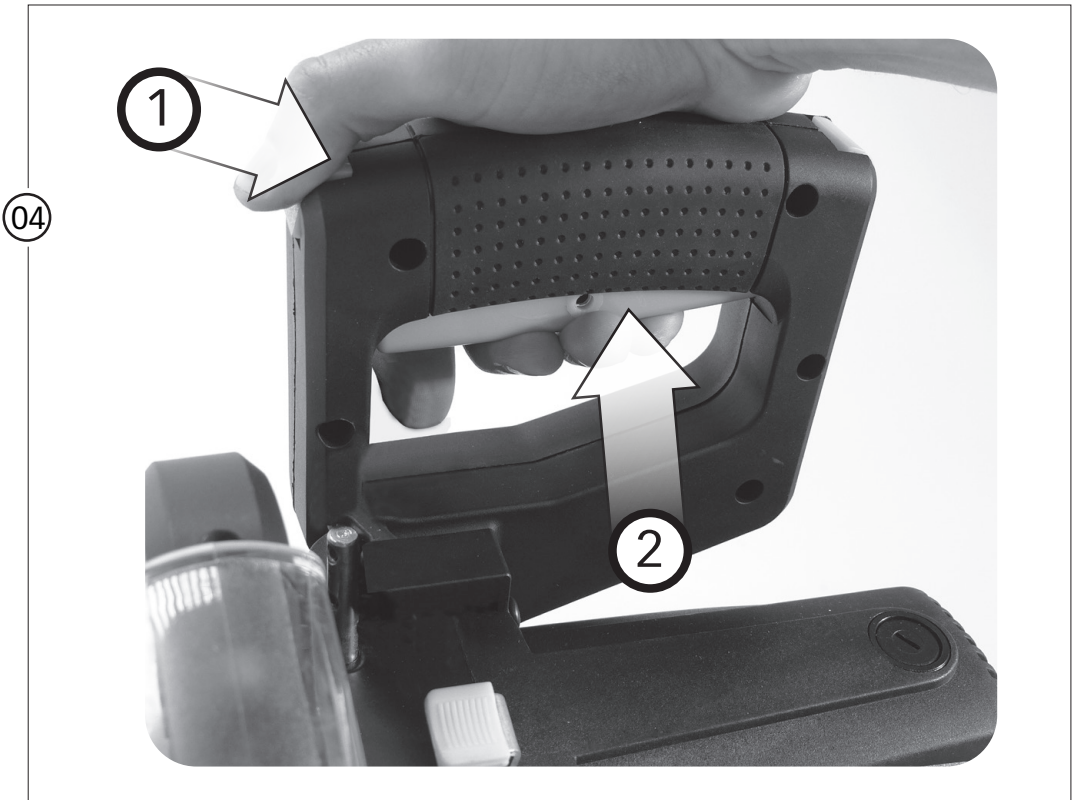
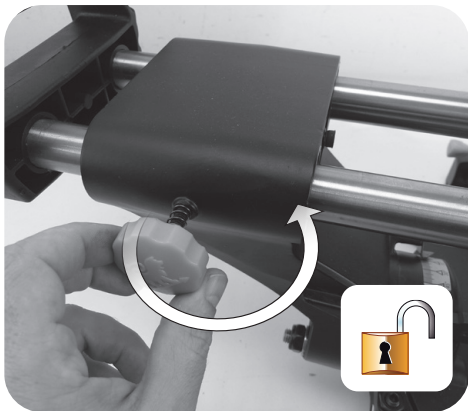

FIG. E



Interrupteur pour gaucher et droitier
Schakel links en rechtshandig
Cambiar izquierda y la mano derecha
Alternar izquierda e derecha handed
Interruttore di sinistra e di mano destra
Switch left and right handed

05



Fonction radiale : capacité de coupe accrue
 Radial functie: verhoogde snijcapaciteit
 Función Radial: mayor capacidad de corte
 Função radial: o aumento da capacidade de corte
 Funzione radiale: aumento della capacità di taglio
 Radial function: increased cutting capacity

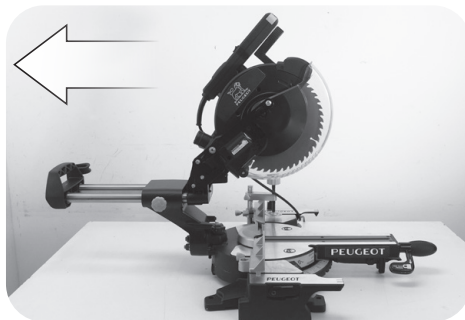

06

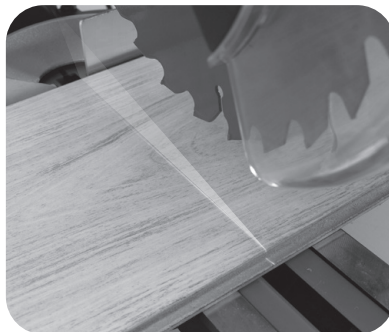
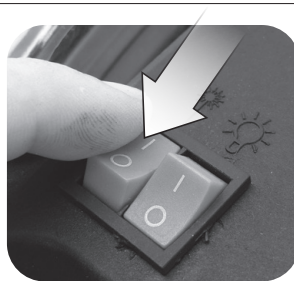
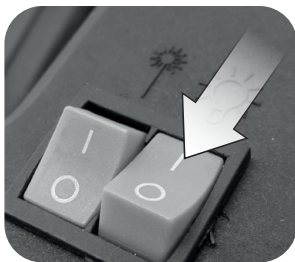

07

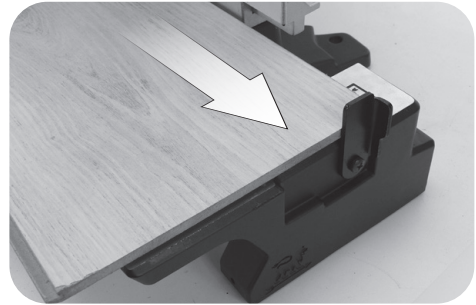
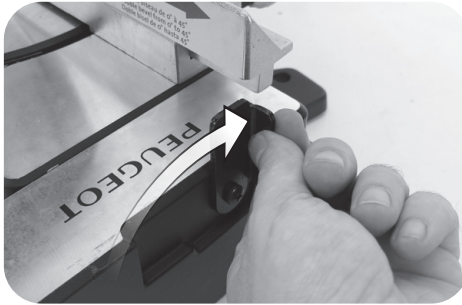

08

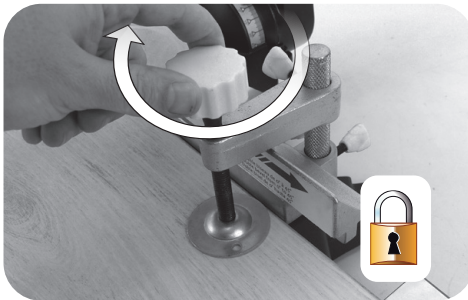
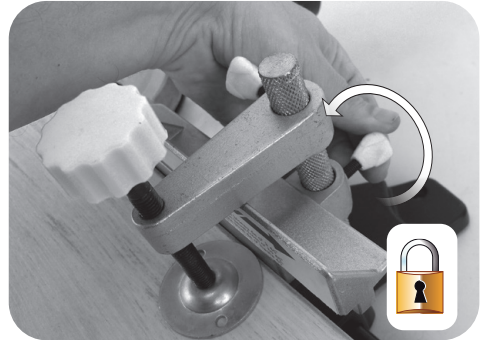
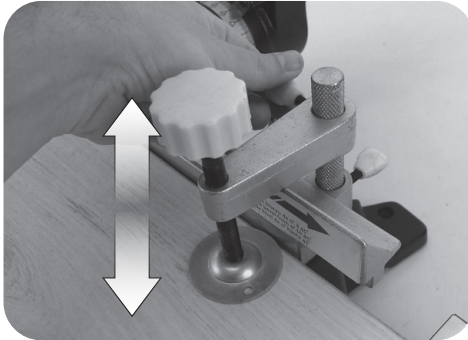

Maintenir fermement la pièce à couper. Abaisser la tête lentement, et scier la pièce de bois à une vitesse régulière (pas d'à-coups). Attendre l'arrêt complet de la lame avant de remonter la tête de la machine lentement.

Stevig vast te houden het werkstuk. Verlagen langzaam zijn hoofd, en zag er een stuk hout met een constant snelheid (niet een eikel). Wacht een volledige stop voordat het blad de kop machine langzaam.

Sujete firmemente la pieza de trabajo. Bajando la cabeza lentamente, y aserrar el trozo de madera a una velocidad constante (sin sacudido). Espere la parada completa antes de volver a subir la hoja de la cabeza de la máquina lentamente. Segure firmemente a peça. Abaixando a cabeça lentamente, e viu ali pedaço de madeira a uma velocidade constante (não é um idiota). Espere uma parada completa antes que a lâmina até a cabeça da máquina lentamente.

Tenere saldamente il pezzo da lavorare. Abbassare lentamente la testa, e vide lì pezzo di legno ad una velocità costante (non un coglione). Attendere il completo arresto prima che la lama la testa della macchina lentamente. Firmly hold the workpiece. Lowering his head slowly, and saw the piece of wood at a steady speed (without jerk). Wait the complete stop of the blade before pull up the machine head slowly.

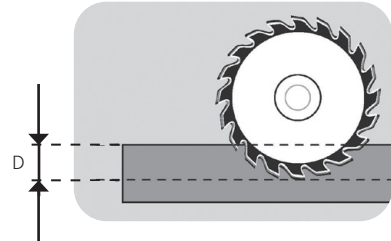
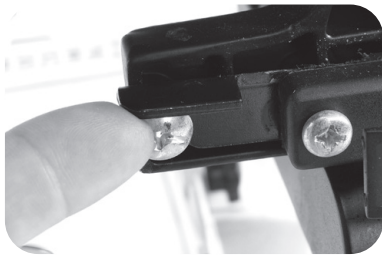
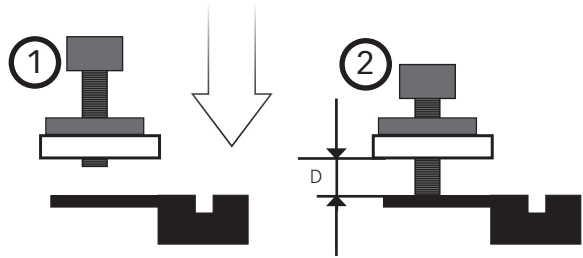
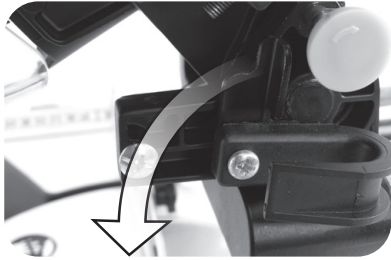

Réglage de la butée de profondeur pour effectuer du rainurage

Aanpassen van de dieptemeter te voeren groovende
 Ajustar el calibre de profundidad para realizar el ranurado
 Ajustar o medidor de profundidade para realizar grooving
 Regolazione del misuratore di profondità per eseguire scanalature
 Adjusting the depth gauge to perform grooving

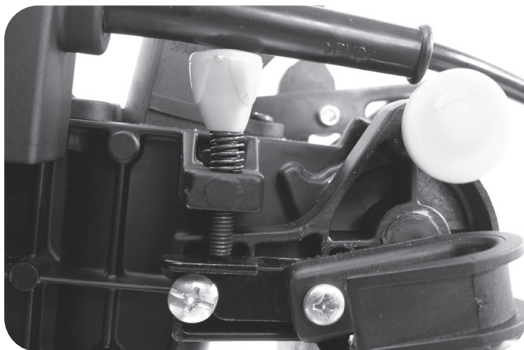
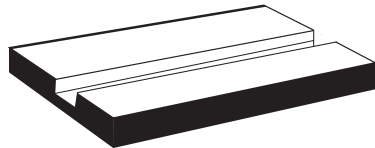

01

Réglage de la butée à 90°

Aanpassing van de aanslag 90°
 Ajuste de la parada de 90°
 Ajustamento do batente 90°
 Regolazione della battuta 90°
 Adjustment of the 90° stop

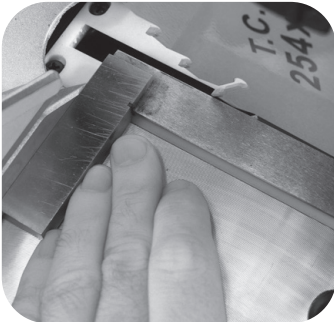
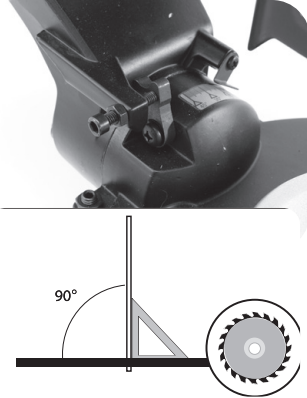

Réglage de la butée à 90°

Aanpassing van de aanslag 90°
 Ajuste de la parada de 90°
 Ajustamento do batente 90°
 Regolazione della battuta 90°
 Adjustment of the 90° stop

Incorrect : réglage nécessaire
 Onjuist: aanpassing vereist
 Incorrecto: se requiere ajuste
 Incorretto: ajuste necessário
 Impossibile: la regolazione è necessaria
 Incorrect: adjustment required



01

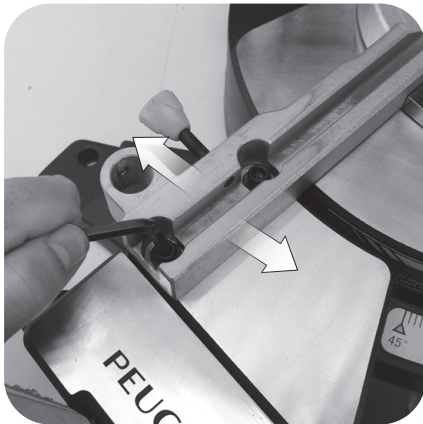

02

Réglage de la butée à 45°
 Aanpassing van de aanslag 45°
 Ajuste de la parada de 45°
 Ajustamento do batente 45°
 Regolazione della battuta 45°
 Adjustment of the 45° stop

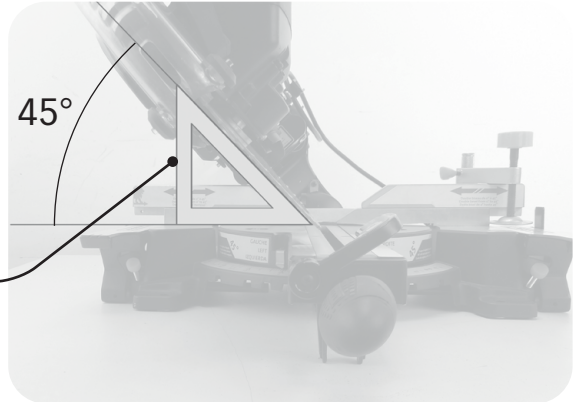
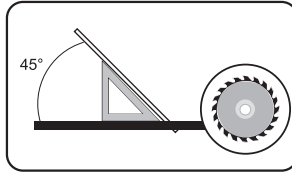
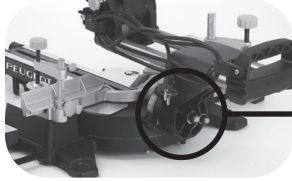
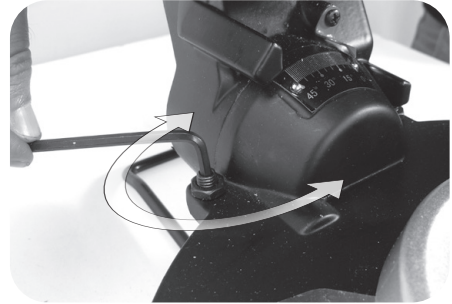

Effectuer le réglage à l'aide d'une équerre
 Verstel met een hoekbeugel
 Ajuste con un soporte angular
 Ajuste com um suporte angular
 Regolare con una staffa ad angolo
 Adjust with an angle bracket



01

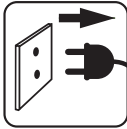

Toujours s'assurer que la machine est débranchée du secteur avant d'effectuer toute opération.

Zich nog steeds wordt ervan overtuigen dat het bekookstoft uitgeschakeld alvorens elke verrichting uit te voeren.
 Siempre asegurarse que la máquina sea desconectada antes de efectuar cualquier operación.
 Sempre assegurar-se que a máquina é desligada antes de efectuar qualquer operação.
 Sempre assicurarsi che la macchina è staccato prima di effettuare ogni operazione.
 Please always make sure that the machine is disconnected before carrying out any operation.

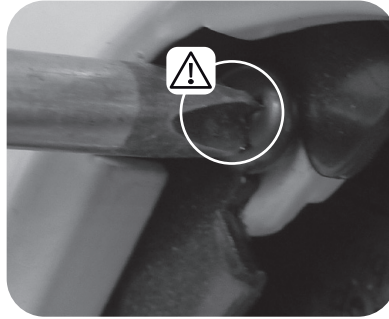
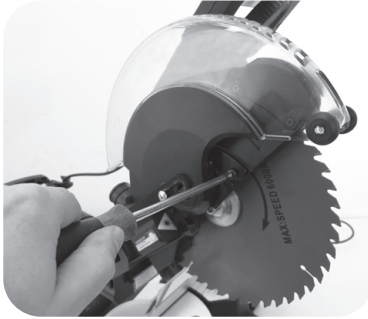

Ne pas enlever la vis
 Draai de schroef Niet te verwijderen
 No retire el tornillo
 Não retire o parafuso
 Non rimuovere la vite
 Don't remove the screw

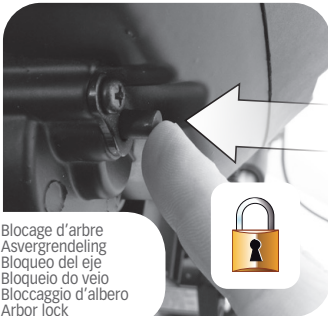
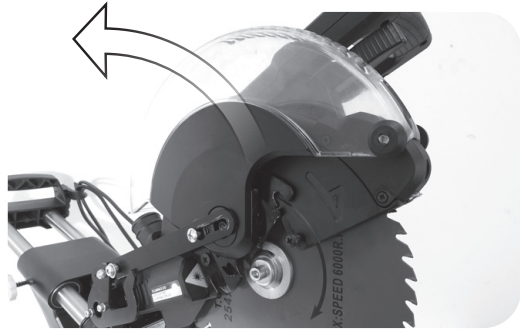
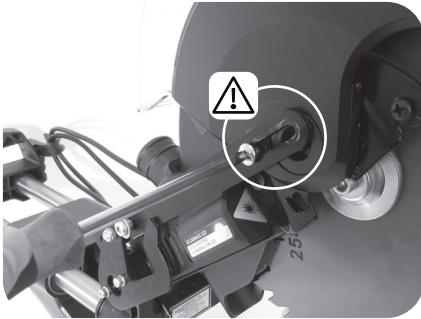

Blocage d'arbre
 Asvergrendeling
 Bloqueo del eje
 Bloqueio do veio
 Bloccaggio d'albero
 Arbor lock

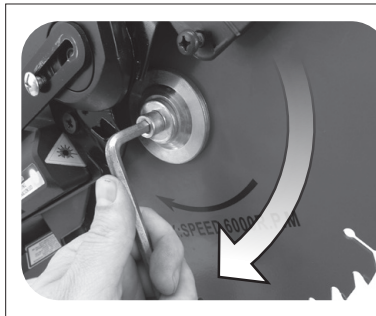

Attention : pas inversé.
 Dévisser dans le sens des aiguilles d'une montre

Waarschuwing: omgekeerde schroefdraad. Schroef in de richting van de klok mee
 Advertencia: rosca invertida. Tornillo en la dirección de las agujas del reloj
 Aviso: rosca inversa. Parafuso no sentido dos ponteiros do relógio
 Attenzione: filetto inverso. Avvitare in direzione oraria
 Warning: reverse thread. Screw in the direction of clockwise

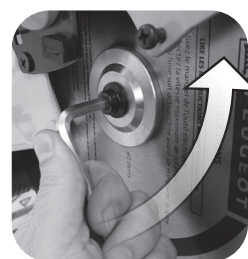
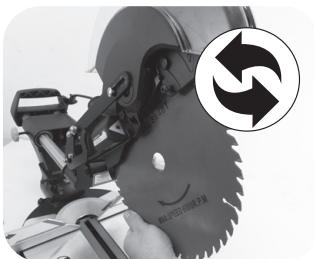

01

ø 254 mm



Ref 801345 - 48 T
 Ref 801346 - 60 T
 Ref 801347 - 80 T

801345 :
 Lame 48 dents pastilles de carbure
 Blade 48 tanden hardmetalen wisselplaten
 Hoja de 48 dientes de carburo de insertos
 Inseire lâmina de 48 dentes de metal duro
 48 T blade
 Lama 48 denti

801346:
 Lame 60 dents pastilles de carbure
 Blade 60 tanden hardmetalen wisselplaten
 Hoja de 60 dientes de carburo de insertos
 Inseire lâmina de 60 dentes de metal duro
 60 T blade
 Lama 60 denti

801347:
 Lame 80 dents pastilles de carbure
 Blade 80 tanden hardmetalen wisselplaten
 Hoja de 80 dientes de carburo de insertos
 Inseire lâmina de 80 dentes de metal duro
 80 T blade
 Lama 80 denti

02

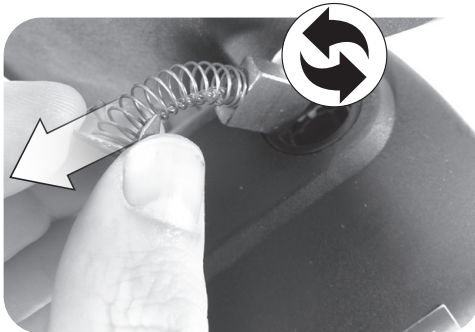

X2



03

Répéter l'opération pour l'autre côté

Herhaal dit voor de andere kant
 Repita para el otro lado
 Repita a operação para o outro lado
 Ripetere l'operazione per l'altro lato
 Repeat operation for the other side

Transport de la machine
 Vervoeren Machine
 Transporte de la máquina
 Transporte da máquina
 Il trasporto della macchina
 Transportation of the Machine

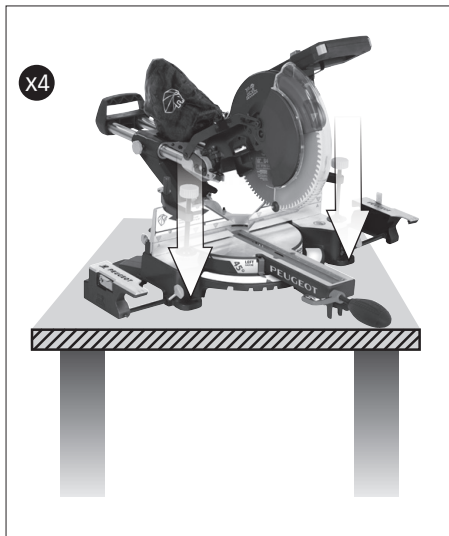

Fixation de l'ensemble
 Vaststelling van de draaibank
 Fijación del torno
 Fixação do Torno
 Fissaggio del tornio
 Fixing the lathe

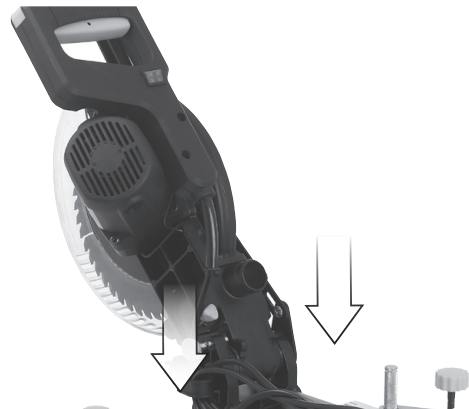



Vider le sac à poussières régulièrement et avant tout nouveau travail !

Leeg de stofzak regelmatig en voordat een nieuw werk!

Vacía la bolsa de polvo con regularidad y antes de cualquier nuevo trabajo!

Esvazie o saco de pó regularmente e antes de qualquer novo trabalho!

Svuotare il sacchetto di polvere regolarmente e prima di ogni nuovo lavoro!

Empty the dust bag regularly and before any new work!

Raccordement à un aspirateur

Aansluiten van een stofzuiger

Conexión de una aspiradora

Conexão de um aspirador de pó

Collegamento di un aspirapolvere

Connecting a vacuum cleaner

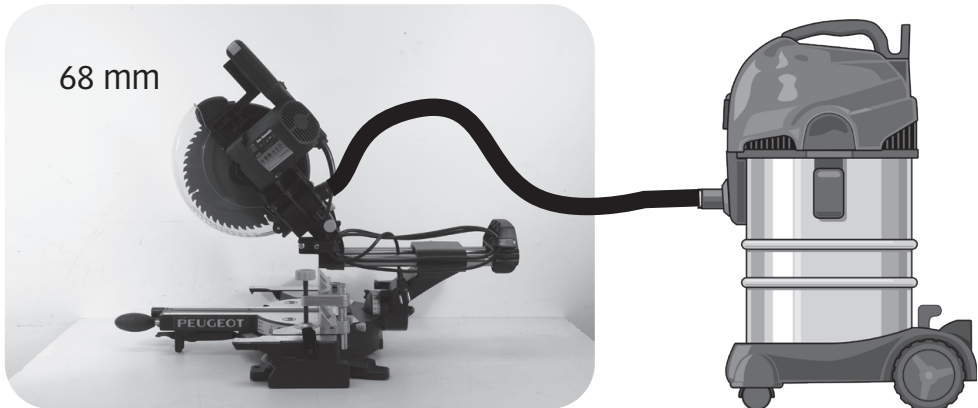

Description et repérage des organes de la machine

FIG. A & B

- 01 Carter de protection
- 02 Interrupteur
- 03 Charbons
- 04 Orientation du plateau
- 05 Verrouillage du plateau
- 06 Butée de longueur
- 07 Presse de serrage
- 08 Graduation du plateau
- 09 Laser
- 10 Inclinaison de la tête
- 11 Ajustement angulaire de la butée
- 12 Fonction radiale
- 13 Extension de table

Contenu du carton

FIG. C

Assemblage de la machine

FIG. D

- 01 Montage du sac à poussières
- 02 Montage butée et extension
- 03 Montage presses de serrage

Fonctionnalité de la machine

FIG. E

- 01 Déverrouillage de la machine
- 02 Orientation du plateau
- 03 Inclinaison de la tête
- 04 Comment faire une coupe
- 05 Comment se servir de la fonction radiale
- 06 Allumage du laser et éclairage LED
- 07 Utilisation des butées
- 08 Maintenir une pièce à couper
- 09 Fonction rainurage

Réglages de la machine

FIG. F

- 01 Régler la coupe à 90°
- 02 Régler la coupe à 45°
- 03 Réglage du laser

Remplacement des consommables

FIG. G

- 01 Changement de lame
- 02 Changement des charbons

Transport et fixation

FIG. H

Entretien, recommandations et conseils

- 01 Ne pas utiliser les scies à onglet pour la coupe de bois de chauffage
- 02 Ne pas forcer sur la machine.
- 03 Il est préférable de relier votre machine à un aspirateur pour collecter le maximum de poussière

Description and location of machine parts

FIG. A & B

- 01 Protection guard
- 02 Switch
- 03 Carbon rods
- 04 Orientation of plate
- 05 Locking of plate
- 06 Length stop
- 07 Clamp
- 08 Plate scale
- 09 Laser
- 10 Angle of head
- 11 Adjustment of stop to 45°/90° angles
- 12 Radial function
- 13 Table extensions

Contents of box

FIG. C

Assembling the machine

FIG. D

- 01 Mounting of dust bag
- 02 Mounting of stops and extensions
- 03 Mounting of clamping vices

Machine Functions

FIG. E

- 01 Unlocking of the machine
- 02 Orientation of plate
- 03 Angle of head
- 04 How to make a cut
- 05 How to use the radial function
- 06 Turning on the laser and LED light
- 07 Using the length stops
- 08 Holding a piece you are cutting
- 09 Groove function

Machine settings

FIG. F

- 01 Adjusting a cut to 90°
- 02 Adjusting a cut to 45°
- 03 Adjusting the Laser

Replacement of consumables

FIG. G

- 01 Changing the blade
- 02 Changing the carbon rods

Fixation and transport

FIG. H

Maintenance, recommendations and advice

- 01 Do not use mitre saws for cutting firewood
- 02 Do not push too hard on the machine.
- 03 It is better to hook your machine up to a vacuum cleaner in order to collect as much dust as possible

Descripción y localización de los elementos

FIG. A & B

- 01 Carter de protección
- 02 Interruptor
- 03 Carbones
- 04 Orientación de la mesa
- 05 Bloqueo de la mesa
- 06 Tope de longitud
- 07 Cárcel
- 08 Graduación de la mesa
- 09 Láser
- 10 Inclinación de la cabeza
- 11 Ajuste angular del tope 45° / 90°
- 12 Función radial
- 13 Extensiones de la mesa

Contenido del cartón

FIG. C

Ensamblaje de la máquina

FIG. D

- 01 Montaje de la bolsa para el polvo
- 02 Montaje de los topes y extensiones
- 03 Montaje de los tornillos de sujeción

Funcionalidad de la máquina

FIG. E

- 01 Desbloqueo de la máquina
- 02 Orientación de la mesa
- 03 Inclinación de la cabeza
- 04 Cómo realizar un corte
- 05 Cómo servirse de la función radial
- 06 Encender el láser
- 07 Utilización de los topes de longitud
- 08 Sujetar la pieza que se tiene que cortar
- 09 Hacer un surco

Configuración de la máquina

FIG. F

- 01 Ajuste del corte a 90°
- 02 Ajuste del corte a 45°
- 03 Ajuste del Láser

Sustitución de consumibles

FIG. G

- 01 Cambio de hoja
- 02 Cambio de los carbones.

Transporte y fijación

FIG. H

Asesoramiento, recomendaciones y mantenimiento

- 01 No utilizar las sierras de ingletes para cortar leña de calefacción
- 02 No ejercer fuerza en la máquina
- 03 Es preferible conectar su máquina a un aspirador para coleccionar la mayor cantidad posible de polvo

Descrizione e localizzazione degli organi

FIG. A & B

- 01 Carter di protezione
- 02 Interruttore
- 03 Carboni
- 04 Orientamento del piano
- 05 Blocco del piano
- 06 Finecorsa di lunghezza
- 07 Morsetti
- 08 Graduazione del piano
- 09 Laser
- 10 Inclinazione della testa
- 11 Regolazione angolare del finecorsa 45° / 90°
- 12 Funzione radiale
- 13 Estensioni del tavolo

Contenuto della scatola

FIG. C

Assemblaggio della macchina

FIG. D

- 01 Montaggio del sacco per polvere
- 02 Montaggio dei finecorsa e delle estensioni
- 03 Montaggio dei morsetti di serraggio

Funzionalità della macchina

FIG. E

- 01 Sblocco della macchina
- 02 Orientamento del piano
- 03 Inclinazione della testa
- 04 Come fare un taglio
- 05 Come usare la funzione radiale
- 06 Accensione del laser
- 07 Utilizzazione dei finecorsa di lunghezza
- 08 Mantenere un pezzo da tagliare
- 09 Funzione Groove

Impostazioni della macchina

FIG. F

- 01 Regolazione del taglio a 90°
- 02 Regolazione del taglio a 45°
- 03 Regolazione del laser

Sostituzione dei consumabili

FIG. G

- 01 Cambiare la lama
- 02 Cambiare i carboni

Trasporto e fissazione

FIG. H

Manutenzione, raccomandazioni e consigli

- 01 Non usare la sega per tagli obliqui per tagliare la legna da ardere
- 02 Non forzare sulla macchina
- 03 Si consiglia di collegare la macchina ad un aspiratore per raccogliere il massimo della polvere

Descrição e identificação dos órgãos

FIG. A & B

- 01 Cáter de proteção
- 02 Interruptor
- 03 Escovas
- 04 Orientação do prato
- 05 Bloqueio do prato
- 06 Fim de curso de comprimento
- 07 Mordente
- 08 Graduação do prato
- 09 Laser
- 10 Inclinação da cabeça
- 11 Ajuste angular do fim de curso 45°/ 90°
- 12 Função radial
- 13 Extensões de mesa

Conteúdo da caixa

FIG. C

Montagem da máquina

FIG. D

- 01 Montagem do saco de poeira
- 02 Montagem dos fins de curso e extensões
- 03 Montagem dos tornos de aperto

Funcionalidade da máquina

FIG. E

- 01 Desbloqueio da máquina
- 02 Orientação do prato
- 03 Inclinação da cabeça
- 04 Como efectuar um corte
- 05 Como utilizar a função radial
- 06 Acendimento do laser
- 07 Utilização dos fins de curso de comprimento
- 08 Imobilizar uma peça a cortar
- 09 Fazer um sulco

Ajuste da máquina

FIG. F

- 01 Ajuste do corte a 90°
- 02 Ajuste do corte a 45°
- 03 Ajuste do laser

Substituição de consumíveis

FIG. G

- 01 Substituição da lâmina
- 02 Mude carvões

Transporte e fixação

FIG. H

Limpeza e manutenção preventiva

- 01 Não utilizar as serras angulares para o corte de lenha
- 02 Não exercer força sobre a máquina
- 03 É preferível ligar a sua máquina a um aspirador, para recolher o máximo de poeira

Beschrijving en plaatsbepaling van de onderdelen

FIG. A & B

- 01 Beschermmantel
- 02 Schakelaar
- 03 Koolborstels
- 04 Richting van de plaat
- 05 Vergrendeling van de plaat
- 06 Lengteaanslag
- 07 Blokkeerinrichting
- 08 Plaatgradering
- 09 Laser
- 10 Hoek van de kop
- 11 Hoekverstelling van de aanslag 45°/ 90°
- 12 Radiale functie
- 13 Tafelverlengingen

Inhoud van het karton

FIG. C

Assemblage van de machine

FIG. D

- 01 Montage van de stofzak
- 02 Montage van de aanslagen en verlengingen
- 03 Montage van de vastzetschroeven

Reiniging en onderhoud

FIG. E

- 01 Ontgrendeling van de machine
- 02 Richting van de plaat
- 03 Hoek van de kop
- 04 Hoe een versnijding te doen
- 05 Hoe de radiale functie te gebruiken
- 06 Aansteken van de laser
- 07 Gebruik van de lengteaanslagen
- 08 Een te versnijden stuk behouden
- 09 Maak een groove

Afstelling van de machine

FIG. F

- 01 Afstelling van het versnijden op 90°
- 02 Afstelling van het versnijden op 45°
- 03 Afstelling van de Laser

Vervanging van de accessoires

FIG. G















- 01 Verandering van de lamel
- 02 Verandering van de koolborstels

Transport en fixatie

FIG. H

Reiniging en onderhoud

- 01 De verstekzagen niet gebruiken voor het versnijden van het brandhout
- 02 De verstekzagen niet gebruiken voor het versnijden van het brandhout
- 03 Het is beter om uw machine te verbinden met een stofzuiger om stof maximaal te verzamelen

<p>EnergySaw-254SB 132033 925525F</p>	<p>Scie à onglets radiale Radiaal verstekzaag Sierra ingletadora radial. Serra a onglete radial Troncatrice radiale Sliding electric mitre saw</p>	 <p>Capacités de coupe : Cutting capacities: Snijden capaciteiten: Capacidades de corte: Cortar capacidades: Di taglio:</p>	<p>90x90° = 78x305 mm 90x45° = 78x210 mm G:45x90° = 78x210 mm G:45x45° = 42x305 mm D:45x45° = 23x210 mm</p>	
	<p>Tension et fréquence assignée : Aangewezen spanning en frequentie: Tensión y frecuencia fijada: Tensão e frequência fixa: Tensione e frequenza assegnata: Nominal frequency and power:</p>	<p>230 V ~ 50 Hz</p>	 <p>Dimensions lame : Blade sizes: Paneel afmetingen: Dimensiones del panel: Dimensões do painel: Dimensioni del pannello:</p>	<p>Ø 254 mm</p>
	<p>Puissance assignée : Nominal power: Leerlaufdrehzahl: Potencia fijada: Potenza assegnata: Potência assinada:</p>	<p>1600 W</p>	 <p>Alésage lame : Bore: Blade boring: Perforación de la lámina: Furo lámina: Foro lama:</p>	<p>Ø 30 mm</p>
	<p>Vitesse à vide : Leerlaufdrehzahl: Velocidad vacía: Velocidade no vácuo: Velocità a vuoto: No-load speed:</p>	<p>4800 min⁻¹</p>	 <p>Danger : Gevaar: Peligro: Perigo: Pericolo: Danger:</p>	<p>X</p>
		<p>60 T</p>	 <p>Conformité européenne : Voldoet aan de EG-normen: Cumple con las directivas CE: Conforme às normas CE: Conforme alle norme CE: Conforms to EC standards:</p>	<p>X</p>
	<p>Laser : Laser: Laser: Laser: Laser: Laser:</p>	<p>X</p>	 <p>Classe d'isolement : 2 Isolatie Klasse: 2 Aislamiento clase: 2 Isolamento classe: 2 Insulation class: 2</p>	<p>X</p>
	<p>Poids : Gewicht: Peso: Peso: Peso: Weight:</p>	<p>17,5 kg</p>	 <p>Lire les instructions avant usage : Lees voor het gebruik de instructies : Léase las instrucciones antes de usar : Ler as instruções antes da utilização : Leggere le istruzioni prima dell'uso : Read the instructions before use :</p>	<p>X</p>
	<p>Risque de sectionnement des doigts ou de la main : Snijden risico van de vinger of hand: Recyclebaar, onder voorbehoud van het sorteren: Seccionamiento riesgo del dedo o de la mano: Risco Seccionamento do dedo ou a mão: Sezionamento rischio del dito o della mano:</p>	<p>X</p>		

	Porter des lunettes de sécurité : Porter un masque anti-poussière: Porter une protection auditive: porter des gants :	x
	Schutzbrille tragen : Staubschutzmaske tragen : Gehörschutz tragen: Handschuhe tragen:	
	Draag een veiligheidsbril : Draag een stofmasker : Draag gehoorbeschermers: draag handschoenen:	
	Llevar puestas gafas protectoras : Llevar puesta una careta de protección contra el polvo : Llevar puesta una protección auditiva: usar guantes	
	Portare de gli occhiali di sicurezza : Indossare una mascherina anti-polvere : Portare una protezione uditiva: indossare i guanti:	
Utilizar óculos de segurança : Utilizar uma máscara anti-poeira : Utilizar uma proteção auditiva: usar luvas:		
Wear protective eyewear : Wear a dust mask : Wear hearing protective equipment: wear gloves :		

	Niveau de pression acoustique :	93,5 dB (A)
	Niveau akoestische druk :	
	Nível de presión acústica :	
	Nível de pressão acústica :	
	Livello di pressione acustica :	
Acoustic pressure level :		

	Niveau de puissance acoustique :	106,5 dB (A)
	Niveau akoestisch vermogen :	
	Nível de potencia acústica :	
	Nível de potência acústica:	
	Livello di potenza acustica:	
Acoustic power level :		

	Niveau de vibration :	2,091 m / s ²
	Trillingsniveau hand/arm :	
	Nível de vibración mano/brazo :	
	Nível de vibração mão/braço :	
	Livello di vibrazione mano/braccio :	
Hand/arm vibration level :		

NIVEAU SONORE D'EMISSION:	A
VIDE	
Pression acoustique LpA poste opérateur	93,5 dB
Incertitude	
3	
Puissance acoustique LWA	106,5 dB
Incertitude	3

Valeurs déterminées suivant le code d'essai de l'annexe B de la norme EN 62841 avec emploi des normes de base ISO 11201 et ISO 3744.

Les niveaux de pression acoustique obtenus in situ dépendent:

- Des niveaux réels de la machine considérées, en prenant en compte les incertitudes déclarées.
- Du local et de l'installation de la machine. Préférez une pièce dont l'acoustique est plus feutrée. Evitez les pièces vide à grande résonance. Placez vous auprès d'une fenêtre le cas échéant.
- Des outils montés, des pièces travaillées, des réglages choisis,...

VIBRATIONS :

Valeur totale des vibrations déterminées conformément au protocole d'essai de la norme EN 62841, pouvant être utilisée pour comparer un outil à un autre et également pour une évaluation préliminaire de l'exposition.

a_n inférieur à 2,5 m/s²
 Incertitude K 1,5 m/s²

Avertissement : l'émission de vibration au cours de l'utilisation réelle de l'outils de puissance peut différer de la valeur totale déclarée, selon les méthodes d'utilisation de l'outil.

Information :

- La ou les valeurs totales déclarées de vibration et la ou les valeurs déclarées d'émission sonore ont été mesurées conformément à une méthode d'essai normalisée et peuvent être utilisées pour comparer des outils ;

- La ou les valeurs totales déclarées de vibration et la ou les valeurs déclarées d'émission sonore peuvent aussi être utilisées dans une évaluation préliminaire de l'exposition.

Mise en garde :

- L'émission de vibration et l'émission sonore pendant l'utilisation de l'outil électrique peuvent être différentes des valeurs déclarées selon les façons d'utiliser l'outil, en particulier le type de pièce à usiner; et
 - Il est nécessaire d'identifier les mesures de sécurité destinées à protéger l'opérateur qui sont basées sur une estimation de l'exposition dans les conditions réelles d'utilisation (en prenant en compte toutes les parties du cycle de manœuvres, telles que les moments où l'outil est hors tension et où il fonctionne à vide, en plus du temps d'actionnement de la manette)

	Sourmis à recyclage :	×
	Niet wegwerpen :	
	Sottoposti a riciclaggio :	
	Sujeitos à reciclagem :	
	Sottoposti a riciclaggio :	
	Subjected to recycling :	

FR-Recyclage des déchets:

Les outils, accessoires et leur emballages doivent suivre une voie de recyclage adaptée. Conformément aux directives Européenne 2012/19/UE et 2006/66/CE, les composants d'un produit doivent être séparés, collectés, recyclés ou éliminés en conformité avec les réglementations environnementales en vigueur. Les appareils, batteries, piles, huiles, emballages devront être déposés dans les systèmes d'élimination des déchets spéciaux tels que déchetteries. Renseignez vous auprès de votre commune pour connaître l'organisme le plus proche à même de retraiter ou de collecter ces déchets.

NI-afval recycling:

Gereedschap, accessoires en verpakkingen moeten volgen een pad geschikt is voor recycling. Volgens de Europese richtlijnen 2012/19/UE en 2006/66/CE, de componenten van een product moet worden gescheiden, verzameld, gerecycleerd of verwijderd in overeenstemming met de milieuvorschriften. Apparaten, batterijen, olie, moet de verpakking worden gedeponeerd in de afvalverwerking afval, zoals stortplaatsen. Neem contact op met uw gemeente naar de dichtstbijzijnde agentschap kunnen herhalen of het verzamelen van deze afvalstoffen te vinden.

ES-Reciclado de los residuos:

Las herramientas, los accesorios y los envases tienen que seguir la vía de reciclaje adecuada. En virtud de las directivas europeas 2012/19/UE y 2006/66/CE, los componentes de un producto deben separarse, recogerse, reciclarse o eliminarse de acuerdo con las regulaciones medioambientales vigentes. Los aparatos, baterías, pilas, aceites, envases deberán llevarse a los centros de eliminación de residuos especiales tales como los ecoparques. Pedir información al municipio par conocer el centro más cercano apto para reciclar o recoger dichos residuos.

PT-Reciclagem do lixo:

As ferramentas, acessórios e suas embalagens devem seguir um canal de reciclagem adaptado. Conformemente às diretivas europeias 2012/19/UE e 2006/66/CE, os componentes de um produto devem ser separados, recolhidos, reciclados ou eliminados de acordo com as regulamentações ambientais em vigor. Os aparelhos, baterias, pilhas, óleos e embalagens deverão ser depositados nos sistemas de eliminação de detritos especiais, tais como unidades de triagem de detritos. Informar-se junto ao seu concelho municipal para conhecer o órgão mais próximo habilitado a evacuar ou recolher estes detritos.

IT-Riciclaggio dei rifiuti:

Gli apparecchi, i loro accessori ed imballaggi devono essere sottoposti ad un processo di riciclaggio appropriato. In conformità con le direttive europee 2012/19/UE e 2006/66/CE, i componenti di un prodotto devono essere separati, raccolti, riciclati o smaltiti in conformità con le normative ambientali in vigore. Gli apparecchi, le batterie, le pile, gli oli, gli imballaggi dovranno essere conferiti nei sistemi di smaltimento dei rifiuti speciali come le isole ecologiche. Informarsi presso il proprio comune per sapere qual è l'ente più vicino in grado di fare il trattamento o la raccolta differenziata di questi rifiuti

EN-Waste recycling:

The tools, accessories and their packaging must use an appropriate recycling channel. In compliance with European Directives 2012/19/UE and 2006/66/CE, a product's components must be separated, collected, recycled or eliminated in accordance with the environmental regulations in force. The appliance, batteries, oils and packaging must be deposited in the special waste elimination systems such as the waste collection centres. Ask your commune for information on the nearest organisation in a position to reprocess or collect this waste

	Recyclable, soumis au tri sélectif:	×
	Recyclable, subject to recycling:	
	Recyclebaar, onder voorbehoud van het sorteren:	
	Reciclable, sin perjuicio de la clasificación:	
	Reciclável, sujeito a triagem:	
	Riciclabile, soggetto a cernita:	

EnergySaw-254SB / 132033

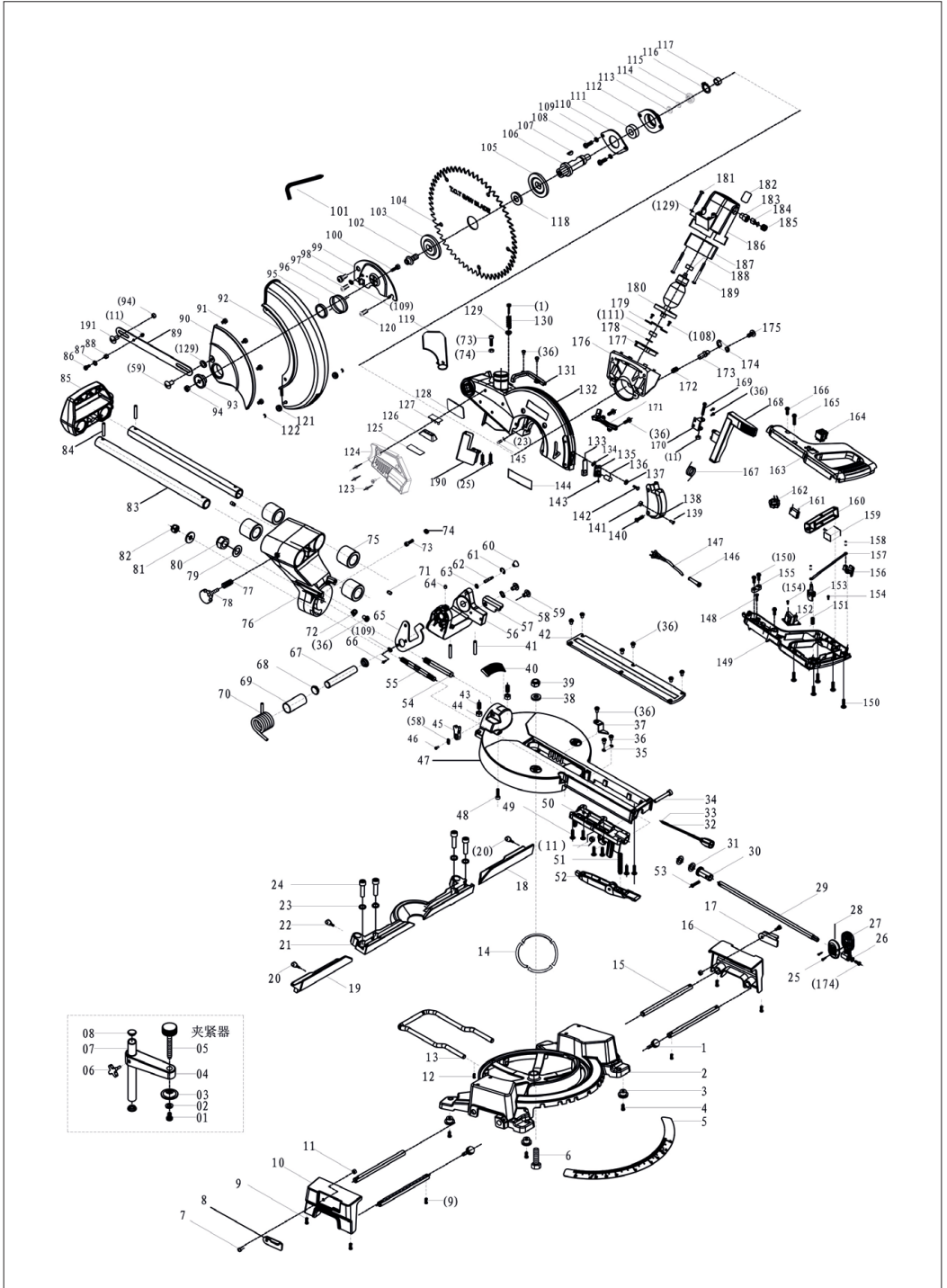

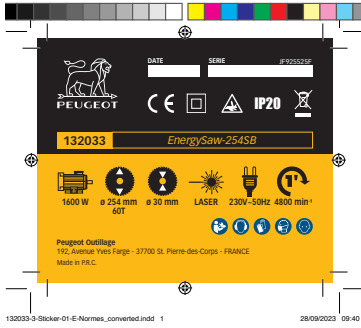

132033-3-Sticker-01-E-Normes_converted.indd 1

28/09/2023 09:40

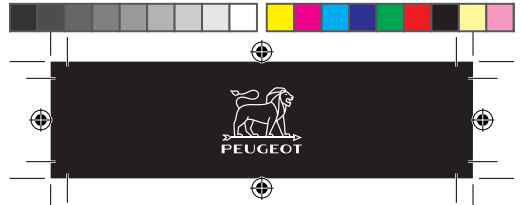

132033-3-Sticker-02-B-Carter.indd 1

02/02/2023 15:45



132033-3-Sticker-03-B-PEUGEOT_plateau.indd 1

02/02/2023 15:58

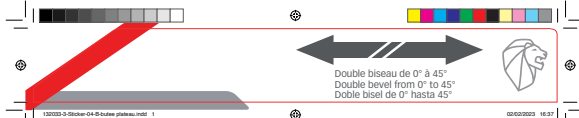

132033-3-Sticker-04-B-Double biseau plateau.indd 1

03/03/2023 16:37

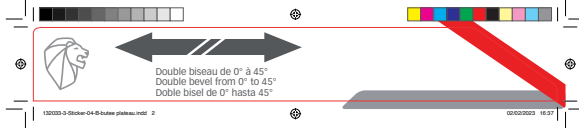

132033-3-Sticker-04-B-Double biseau plateau.indd 2

03/03/2023 16:37



132033-3-Sticker-08-B-Eclairage LED.indd 1

02/02/2023 17:15

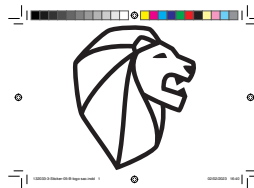

132033-3-Sticker-09-B-Logo.indd 1

02/02/2023 17:15

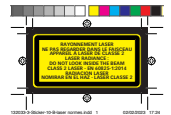

132033-3-Sticker-10-B-Warning symbol.indd 1

02/02/2023 17:15



132033-3-Sticker-06-B-Gauche (Left).indd 1

03/03/2023 17:04



132033-3-Sticker-06-B-Droite (Right).indd 2

03/03/2023 17:04

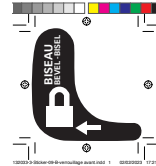

132033-3-Sticker-07-B-Bevel (Left).indd 1

03/03/2023 17:04



132033-3-Sticker-07-B-Bevel (Right).indd 2

03/03/2023 17:04

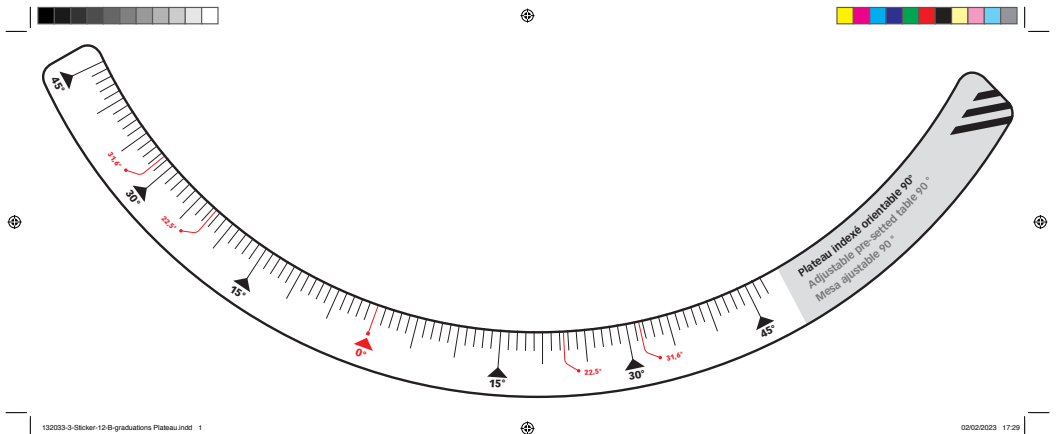

132033-3-Sticker-12-B-graduations Plateau.indd 1

02/02/2023 17:29



**DECLARATION CE DE CONFORMITE
DECLARACION DE CONFORMIDAD
DICHIARAZIONE DI CONFORMITA**

**VERKLARING VAN OVEREENSTEMMING
DECLARAÇÃO DE CONFORMIDADE
DECLARATION OF CE CONFORMITY**

Le soussigné,
Ondergetekende,
El suscrito,
O abaixo assinado,
Il sottoscritto,
The undersigned,

PEUGEOT OUTILLAGE

192, Avenue Yves Farge - 37700 St. Pierre-des-Corps - FRANCE
Tél. : 02 36 16 71 46 - Fax : 02 36 16 71 40

Déclare par la présente que,
Verklaart hiermede dat,
Declaro por la presente, que,
Declara pela presente que,
Dichiari che,
Declares that,

CODE

PEUGEOT / 132033 / EnergySaw-254SB / JF925525F

Scie à onglets radiale / Sliding electric mitre saw / Sierra ingletadora radial
Serra a onglete radial / Troncatrice radiale / Radiaal verstekzaag

Est conforme et satisfait aux normes CE:
In overeenstemming is met en Voldoet aan EG richtlijnen:
Cumple con la directivas de la CE:
Respeita e está em conformidade com as normas CE:
È conforme alle direttive CEE:
Complies with the EEC standards:



Machine :
Machine:
Máquina:
Máquina:
Macchina:
Machine :

2006/42/EC 2014/30/EU 2011/65/EU 2015/863/EU
EN 62841-1:2015
EN IEC 62841-3-9:2020/A11:2020
EN IEC 55014-1:2021
EN IEC 55014-2:2021
EN IEC 61000-3-2:2019/A1:2021
EN IEC 61000-3-11:2019

SIGMA
Présidente de PEUGEOT OUTILLAGE
Représentée par son Président :
Christophe HUREL
21/04/2023
Fait à St. Pierre-des-Corps

Personne autorisée à
constituer le dossier technique :
Christophe HUREL

5 ANS 10 ANS



GARANTIE / RÉPARABILITÉ

BON DE GARANTIE

1 - Objet de la garantie :
La garantie porte exclusivement sur les vices de fabrication ou les vices de matières.
Elle nous oblige à l'échange ou à la réparation des pièces reconnues hors d'usage.

2 - Durée de la garantie :
La garantie est de 60 mois à dater de la livraison du matériel à l'utilisateur (facture ou ticket de caisse à fournir). Les échanges ou réparations faites au titre de la garantie ne peuvent avoir pour effet de prolonger celle-ci.
Les frais de port ALLER sont à la charge de l'utilisateur.

3 - Réserves :
La garantie ne s'applique en aucun cas aux réparations effectuées en dehors de nos réparateurs agréés.
En aucun cas, durant la période de garantie, le matériel ne devra être démonté.

GARANTIEKAART

1 - Doel van de garantie:
De garantie heeft uitsluitend betrekking op fabricagefouten of gebreken in materialen.
Het dwingt ons om uit te wisselen of reparatie van erkende onbruikbare onderdelen.

2 - Duur van de garantie:
De garantie bedraagt 60 maanden vanaf de levering van apparatuur voor de gebruiker (factuur of kassabonnetje verstrekken).
De uitwisseling of reparaties onder garantie niet te verlenen.
GO verzendkosten zijn voor rekening van de gebruiker.

3 - Reserves:
De garantie geldt niet in alle reparaties die buiten onze goedgekeurde reparateurs.
In ieder geval gedurende de garantie, moet het materiaal worden verwijderd.

TARJETA DE GARANTÍA

1 - Objeto de la garantía:
La garantía sólo se referirá a los defectos de fabricación o defectos en los materiales.
Nos obliga a cambiar o reparación de las piezas fuera de servicio reconocido.

2 - Duración de la garantía:
La garantía es de 60 meses a partir de la entrega de equipos para el usuario (factura o recibo que se den).
Los intercambios o reparaciones bajo garantía no tendrá que prolongarse.
GO gastos de envío correrán a cargo del usuario.

3 - Reservas:
La garantía no se aplica en todas las reparaciones realizadas fuera de nuestros talleres de reparación autorizados.
En cualquier caso, durante el período de garantía, el material debe ser removido.

CARTÃO DE GARANTIA

1 - Finalidade da garantia:
A garantia só relacionar com defeitos de fabricação ou defeitos em materiais.
Ela nos obriga a troca ou reparo de peças inservíveis reconhecidos.

2 - Duração da Garantia:
A garantia é de 60 meses a partir da entrega de equipamentos para o usuário (factura ou recibo a ser fornecido). Trocas ou reparos sob a garantia não terá que prorrogá-la.
GO porte serão custeadas pelo usuário.

3 - Reservas:
A garantia não se aplica a quaisquer reparos feitos fora das nossas oficinas aprovadas.
Em qualquer caso, durante o período de garantia, o material deve ser removido.

GARANZIA

1 - Oggetto della garanzia:
La garanzia si riferisce esclusivamente alla difetti di fabbricazione o difetti nei materiali.
Ci costringe a scambio o la riparazione di parti inutilizzabili riconosciuti.

2 - Durata della garanzia:
La garanzia è di 60 mesi dalla consegna delle attrezzature per l'utente (fattura o ricevuta da fornire).
Scambi o riparazioni in garanzia non sarà necessario prolungarla.
GO spese di spedizione sono a carico dell'utente.

3 - Riserve:
La garanzia non si applica in tutte le riparazioni effettuate al di fuori dei nostri riparatori autorizzati.
In ogni caso, durante il periodo di garanzia, il materiale deve essere rimosso.

WARRANTY

1 - Scope of the warranty :
The warranty shall only apply to manufacturing defects or material defects.
We are obliged to exchange or repair parts that are identified as being unusable

2 - Lifetime warranty :
The warranty shall be valid for 60 months from the delivery date of the equipment to the user (invoice or till receipt must be provided).
Exchanges or repairs carried out under the warranty shall not extend the original warranty period.
The user shall be responsible for original shipping charges.

3 - Reservations :
The warranty shall not under any circumstances cover repairs carried out by a non-authorized repairer.
The equipment should not be dismantled under any circumstances during the warranty period.

Date d'achat	Référence machine	Cachet du distributeur
Datum van aankoop	Machine referentie	Dealer stempel
Fecha de compra	Referencia de la máquina	Comerciante de sellos
Data da compra	Referência de máquina	Selo Revendedor
Data di acquisto	Riferimento macchina	Timbro del rivenditore
Purchase date	Machine code	Distributor's stamp

SERVICE APRÈS VENTE - AFTER SALE SERVICE

PEUGEOT OUTILLAGE - 192, Avenue Yves Farge - 37700 St. Pierre-des-Corps - FRANCE - Tél. : 02 36 16 71 46 - Fax : 02 36 16 71 40





PEUGEOT OUTILLAGE

Une société du groupe **SIGMA**

192, Avenue Yves Farge
37700 St. Pierre-des-Corps
FRANCE

peugeot-outillage.com

