



EnergyPlane-305ASP



PEUGEOT OUTILLAGE

132455-2-D-20240112

FR MANUEL D'UTILISATION (Notice originale):
NL HANDBOEK (Vertaling van het oorspronkelijke):
ES MANUAL (Traducción del original):
PT MANUAL (Tradução do manual original):
IT MANUAL (Traduzione dell'avvertenza originale):
EN USING MANUAL (Original manual translation):

Raboteuse Dégauchisseuse
Elektrische Schaafmachine
Cepilladora Desalabeadora
Maquina de Aplainar
Pialla elettrica
Planer thicknesser



VIDEO

AIDE AU MONTAGE MACHINE

HOW TO ASSEMBLE MACHINE

Flashez le code ci dessous, ou rendez vous sur l'adresse suivante :
Flash the code below, or go to the following address:

<https://youtu.be/3rCepu0itCA>





A

Description et repérage des organes de la machine

Description and location of machine parts

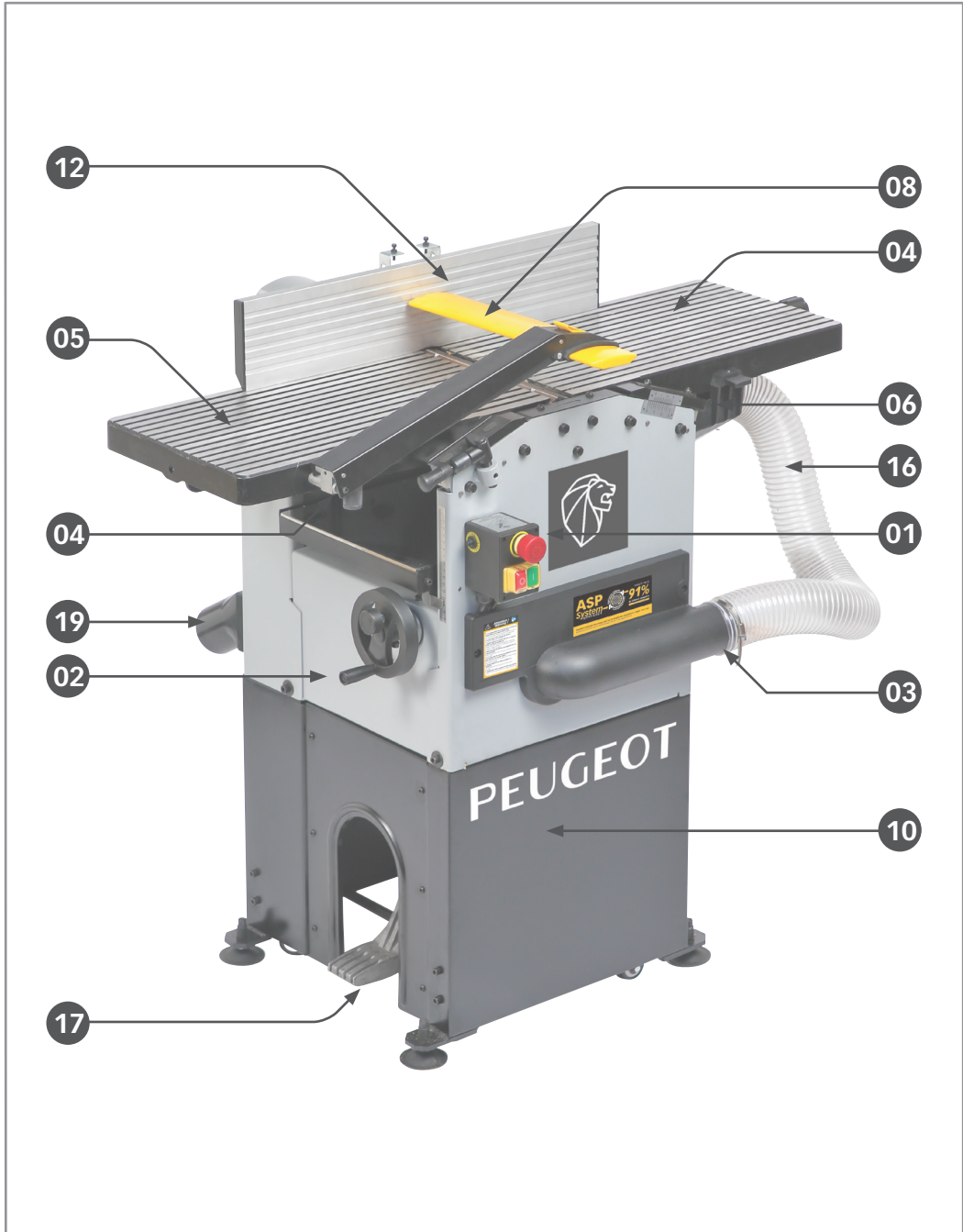

**B**

Description et repérage des organes de la machine

Description and location of machine parts

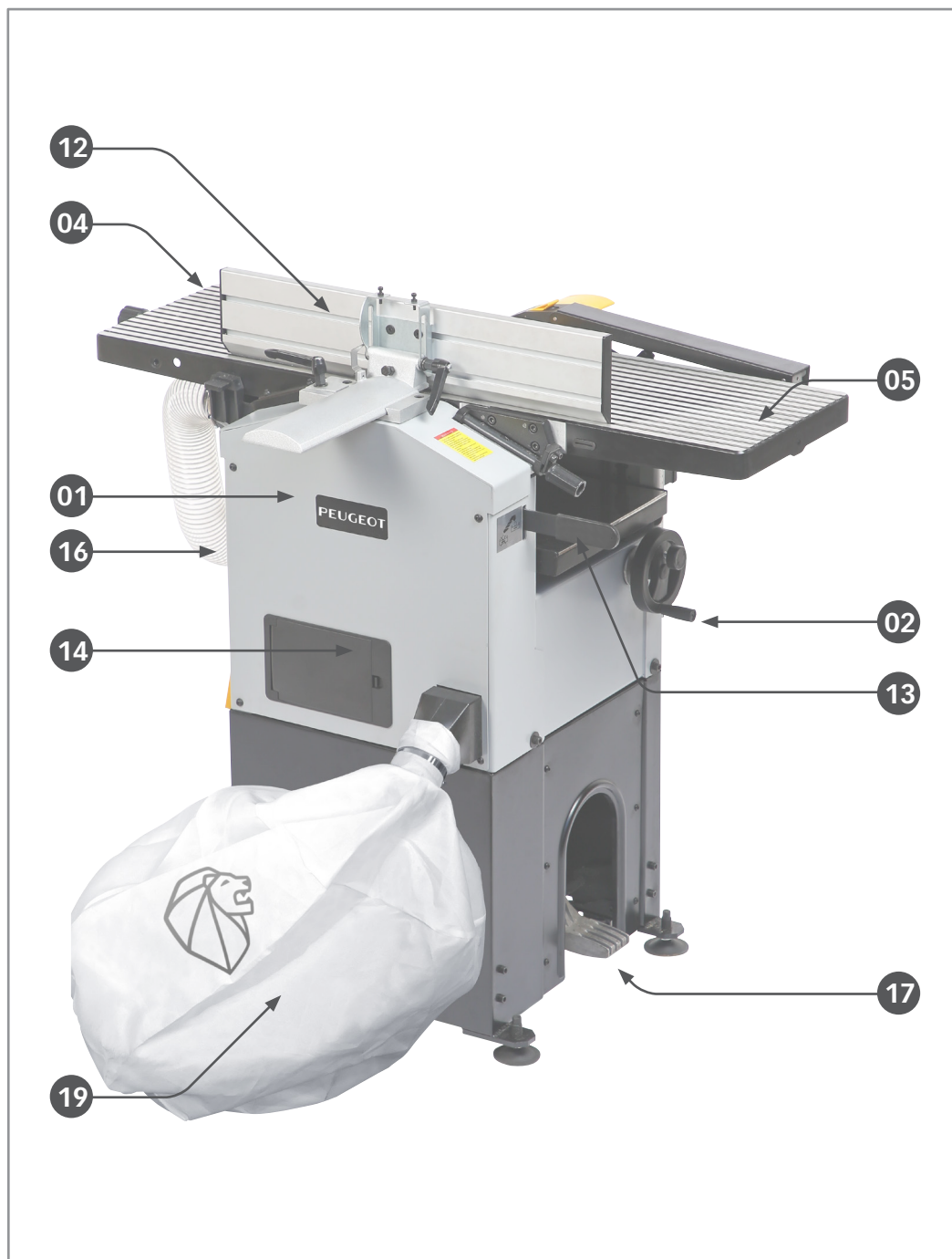



C

Contenu du carton
Contents of box

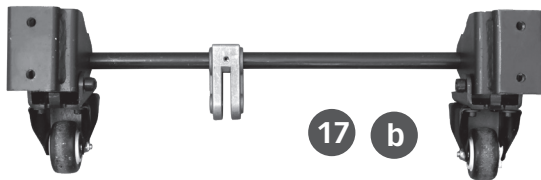
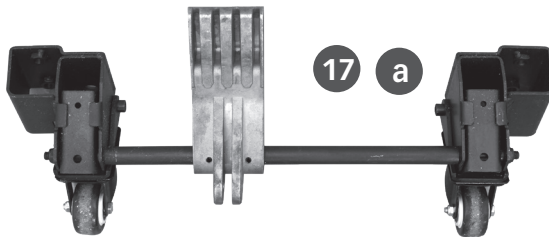



C

Contenu du carton Contents of box



06



16

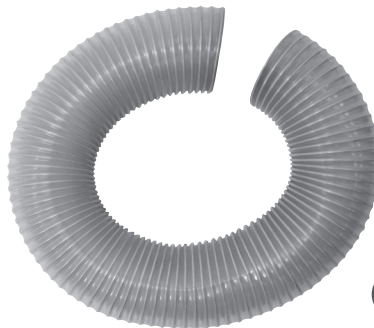

22



08



18



19 b



20 x 4



21 x 2



19 a

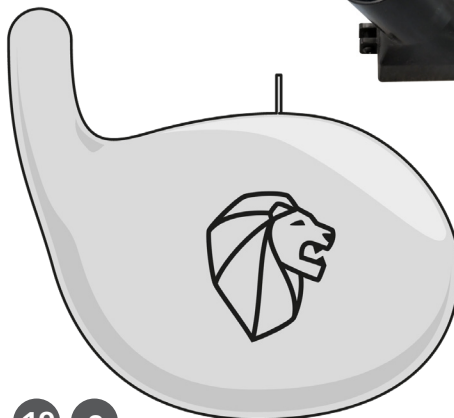

Points de collecte sur www.quefairemesdechets.fr
Privilégiez la réparation ou le don de votre appareil !



D

Assemblage de la machine *Machine assembly*



Assemblage du bâti

Frame montage
Conjunto de marco
Montagem de quadro
Assemblaggio del telaio
Frame assembly

01

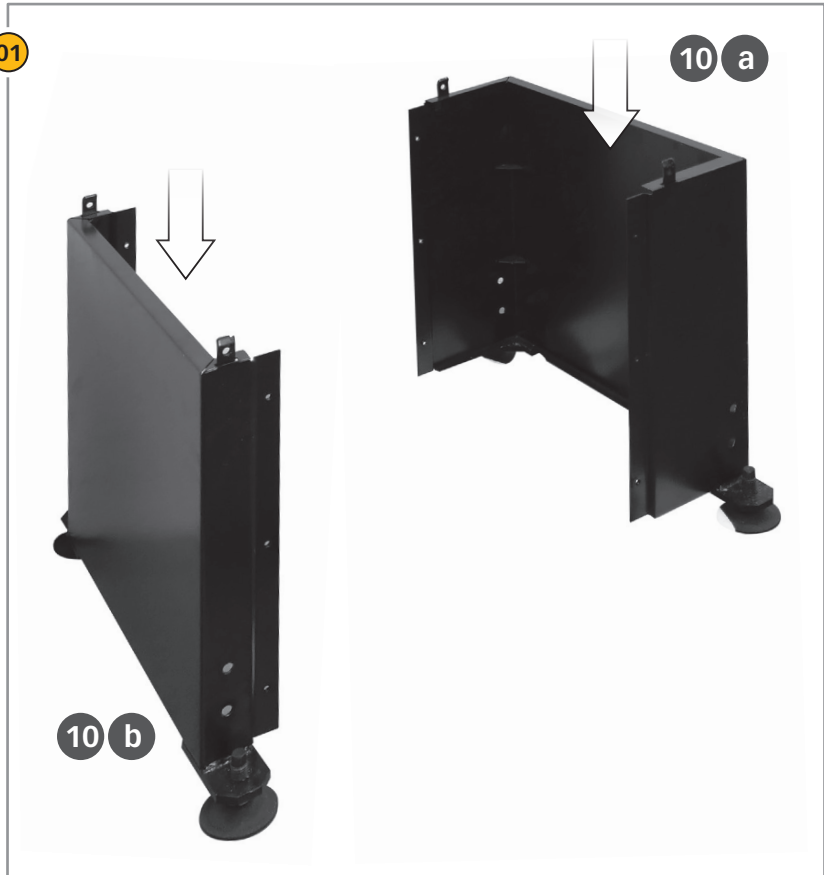

10 d

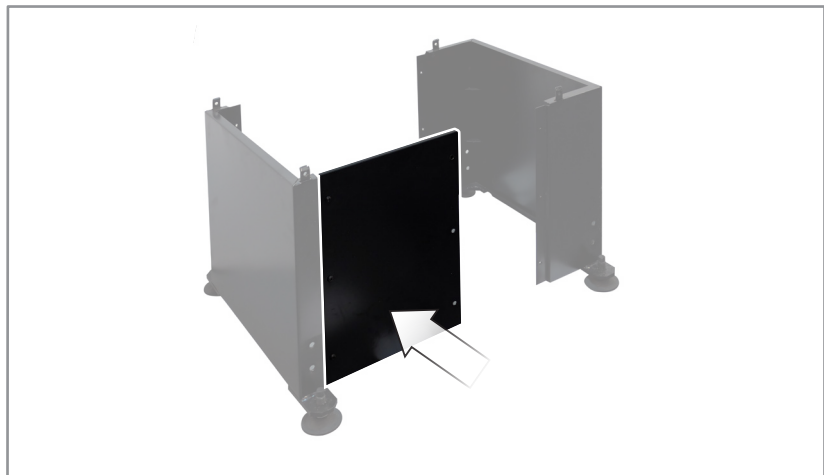



D

Assemblage de la machine Machine assembly



Assemblage du bâti

Frame montage
Conjunto de marco
Montagem de quadro
Assemblaggio del telaio
Frame assembly



10 e

x 3

02

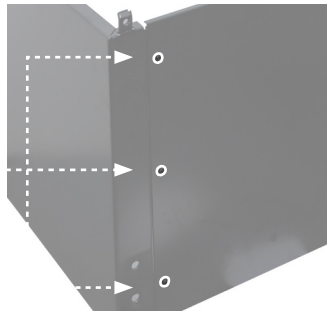

03

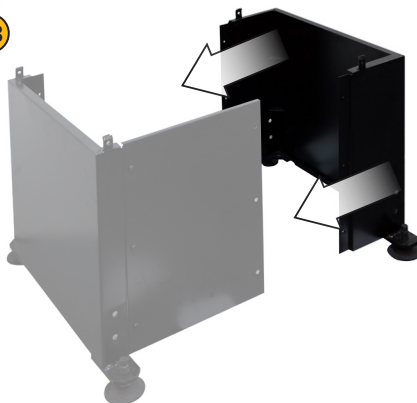

10 e

x 3

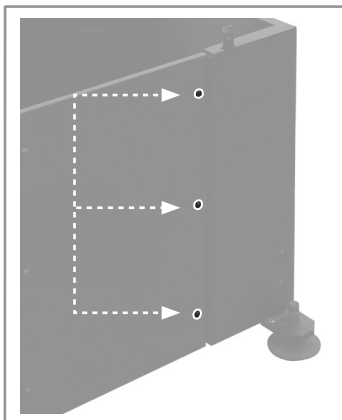

OK





D

Assemblage de la machine Machine assembly



Assemblage du bâti

Frame montage
Conjunto de marco
Montagem de quadro
Assemblaggio del telaio
Frame assembly

04

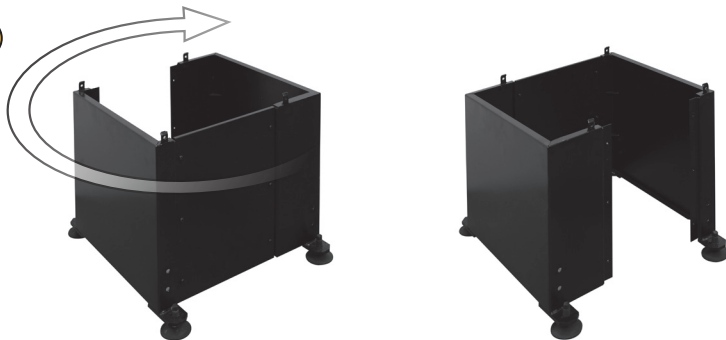

05



10 c

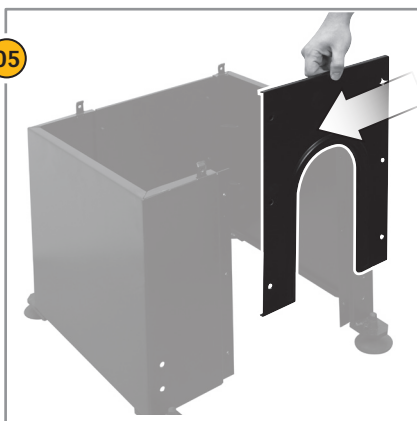

X6



10 e

x 6

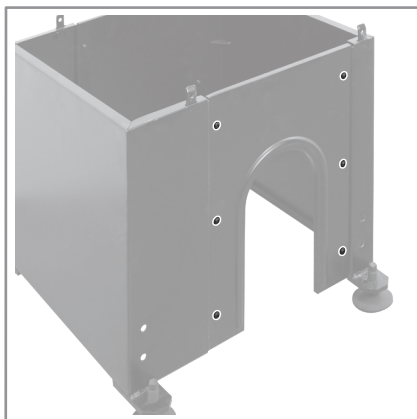

OK



Une fois le bâti assemblé, bien serrer les 12 vis.
Zodra het frame is gemonteerd, draait u de 12 schroeven stevig vast.
Una vez que el marco esté ensamblado, apriete firmemente los 12 tornillos.
Assim que a estrutura estiver montada, aperte os 12 parafusos com firmeza.
Una volta che il telaio è assemblato, serrare saldamente le 12 viti.
Once the frame is assembled, tighten the 12 screws securely.





D

Assemblage de la machine *Machine assembly*



Assemblage des roues

Wiel montage
Montaje de rueda
Conjunto de roda
Assemblaggio ruote
Wheels assembly

01

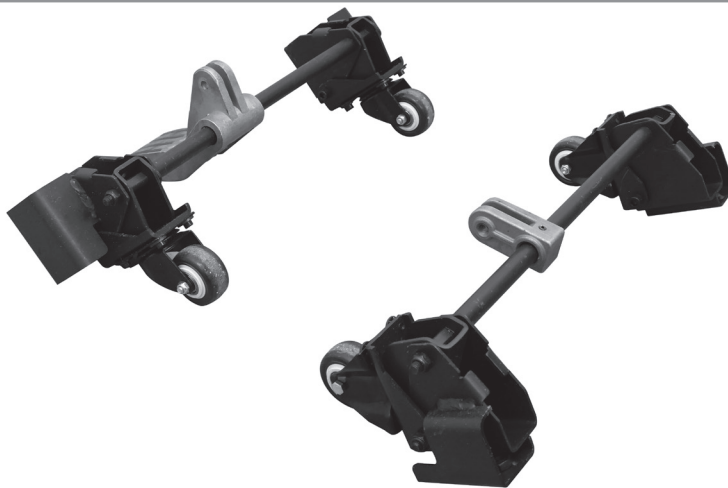

02



17

C

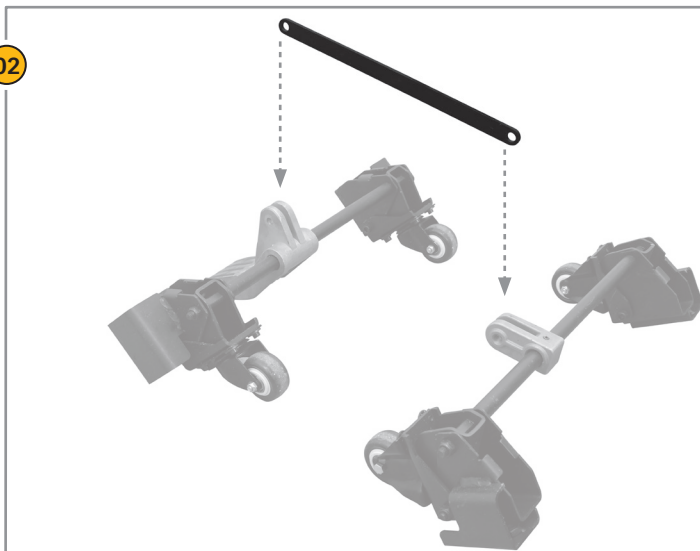

OK





D

Assemblage de la machine Machine assembly

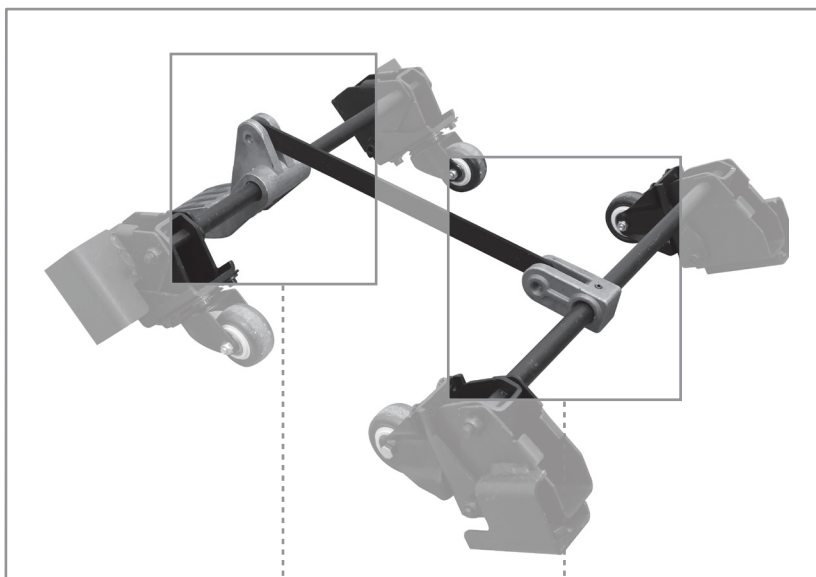

03



17 d

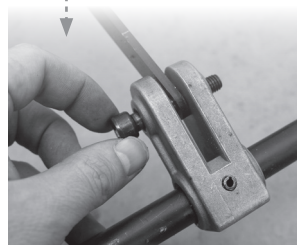
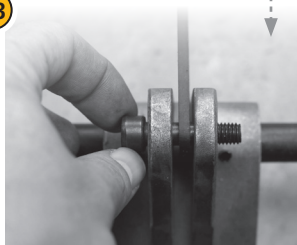

04

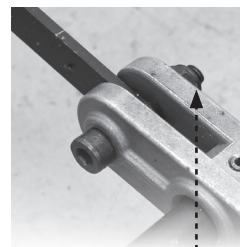
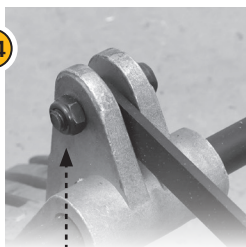



D

Assemblage de la machine Machine assembly



Assemblage des roues

Wiel montage
Montaje de rueda
Conjunto de roda
Assemblaggio ruote
Wheels assembly

01

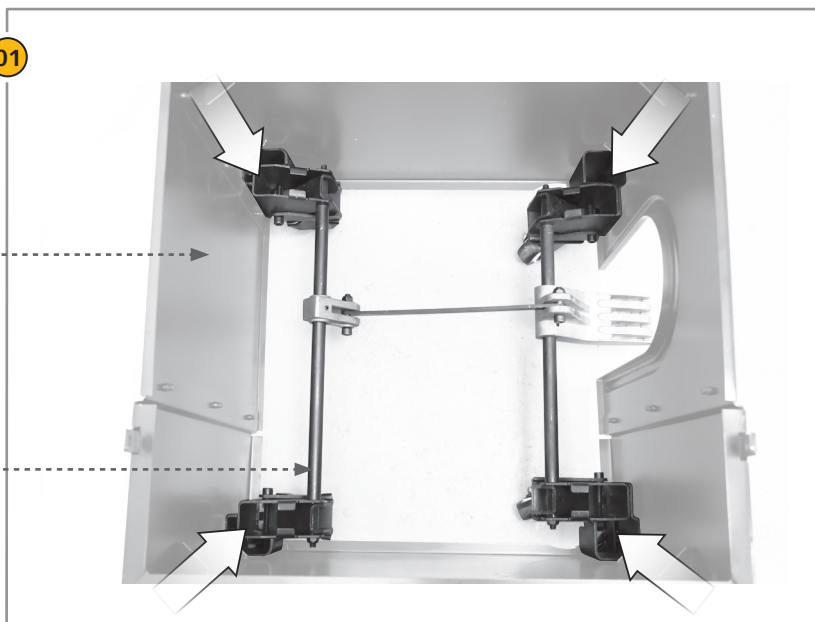

Avant de fixer définitivement l'ensemble des roues, veiller à ce que la pédale soit en position relevée.

Voordat u alle wielen definitief bevestigt, moet u ervoor zorgen dat het pedaal omhoog staat.
Antes de fijar permanentemente todas las ruedas, asegúrese de que el pedal esté en la posición elevada.
Antes de fijar permanentemente todas as rodas, certifique-se de que o pedal esteja na posição elevada.
Prima di fissare definitivamente tutte le ruote, assicurarsi che il pedale sia in posizione sollevata.
Before permanently fixing all the wheels, make sure that the pedal is in the raised position.





D

Assemblage de la machine

Machine assembly



Assemblage des roues

Wiel montage
Montaje de rueda
Conjunto de roda
Assemblaggio ruote
Wheels assembly

02

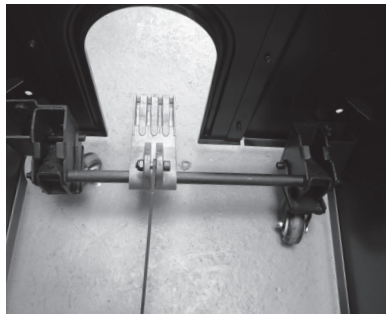
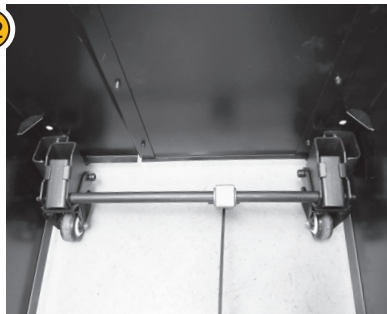

03



17 e

x 8

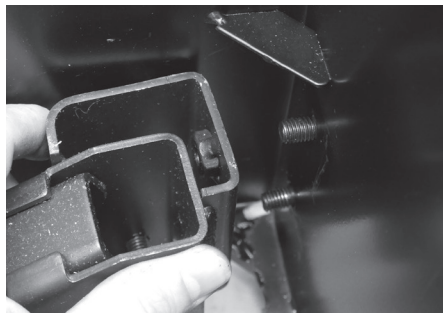
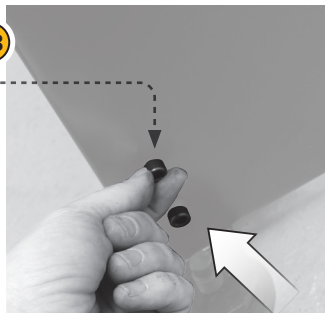

04

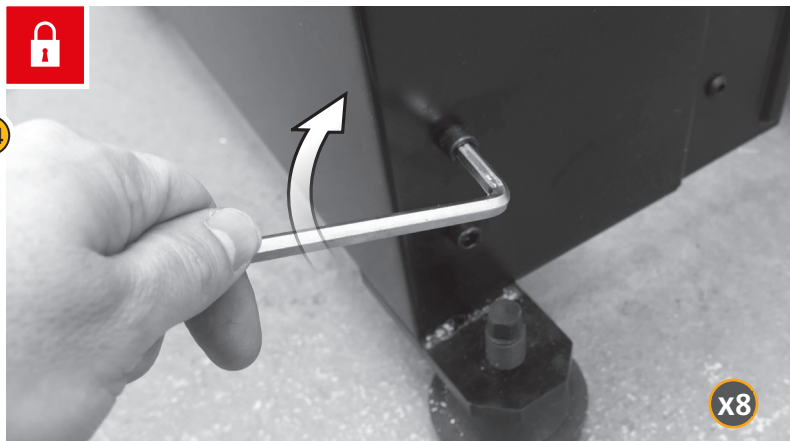

x8

Bien serrer les 4 vis de chaque coté (8 vis en tout)
Apriete los 4 tornillos de cada lado (8 tornillos en total)
Apriete los 4 tornillos de cada lado (8 tornillos en total)
Aperte os 4 parafusos de cada lado (8 parafusos no total)
Serrare le 4 viti su ciascun lato (8 viti in tutto)
Tighten the 4 screws on each side (8 screws in all)

**D**

Assemblage de la machine

Machine assembly



Montage du robot

Schaafmachine montage
Montaje de cepilladora
Montagem da plaina
Assemblaggio pialla
Planer assembly

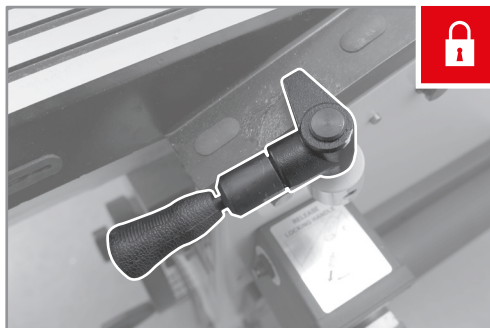
01**OK**

Vérifier que la table de dégauchissage est bien verrouillée avant de soulever la machine

Controleer of de schaaftafel goed is vergrendeld voordat u de machine optilt
Compruebe que la mesa de cepillado esté bloqueada de forma segura antes de levantar la máquina.
Verifique se a mesa de aplainamento está travada com segurança antes de levantar a máquina
Controllare che il piano di piallatura sia bloccato saldamente prima di sollevare la macchina
Check that the planing table is securely locked before lifting the machine

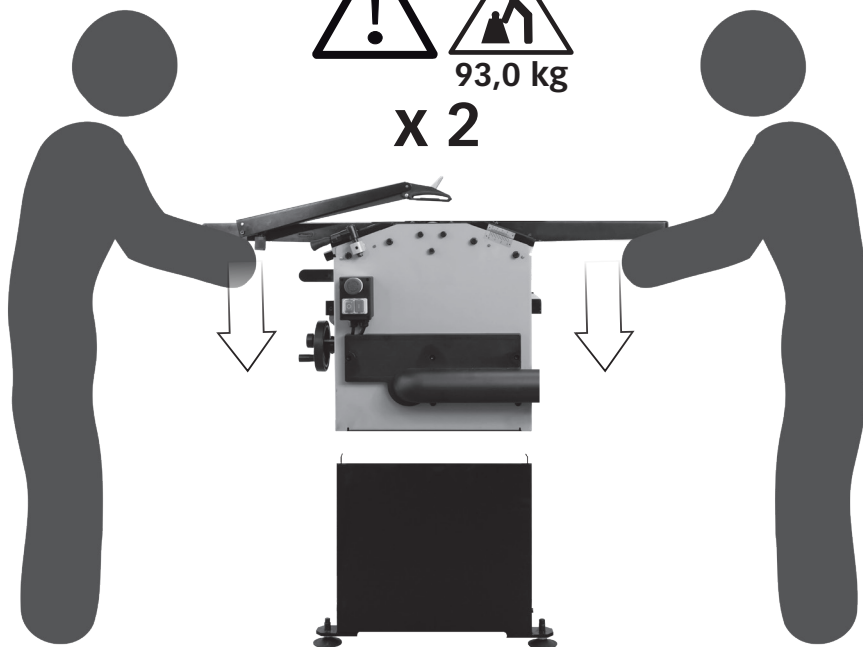
**93,0 kg****x 2**

Le montage de cette machine sur son support nécessite obligatoirement l'intervention de deux personnes !

De montage van deze machine op zijn steun vereist noodzakelijkerwijs de tussenkomst van twee personen!
¡El montaje de esta máquina sobre su soporte requiere necesariamente la intervención de dos personas!
A montagem desta máquina no seu suporte requer obrigatoriamente a intervenção de duas pessoas!
Il montaggio di questa macchina sul suo supporto richiede necessariamente l'intervento di due persone!
The assembly of this machine on its support necessarily requires the intervention of two people!





D

Assemblage de la machine Machine assembly



Montage du robot

Schaafmachine montage
Montaje de cepilladora
Montagem da plaina
Assemblaggio piatta
Planer assembly



20





D

Assemblage de la machine Machine assembly



Montage du robot

Schaafmachine montage
Montaje de cepilladora
Montagem da plaina
Assemblaggio pialla
Planer assembly

03



20



X4

Assemblage du guide

Gids montage
Montaje de guía
Montagem de guia
Montaggio guida
Guide assembly

01

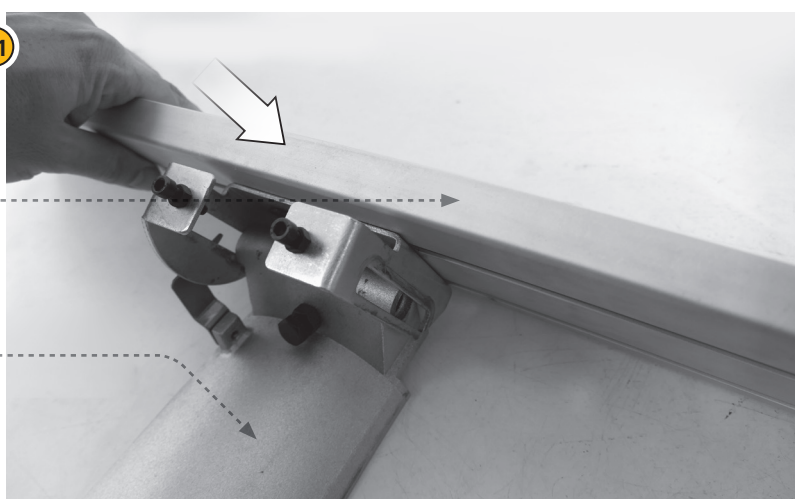

12

a



12

b

02

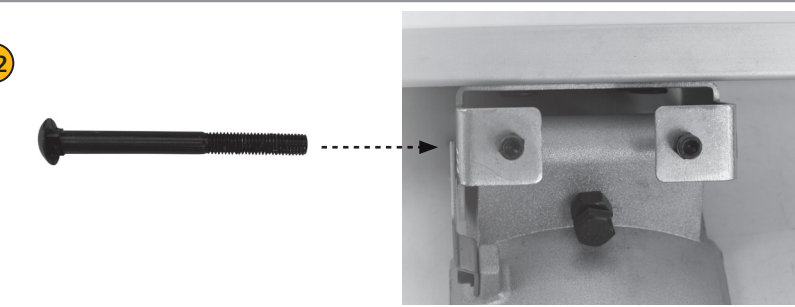



D

Assemblage de la machine Machine assembly



03

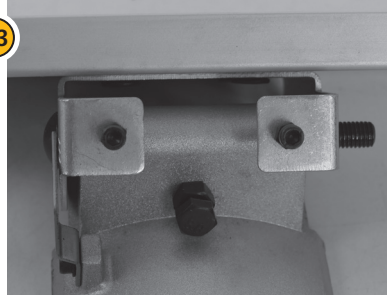

12 C

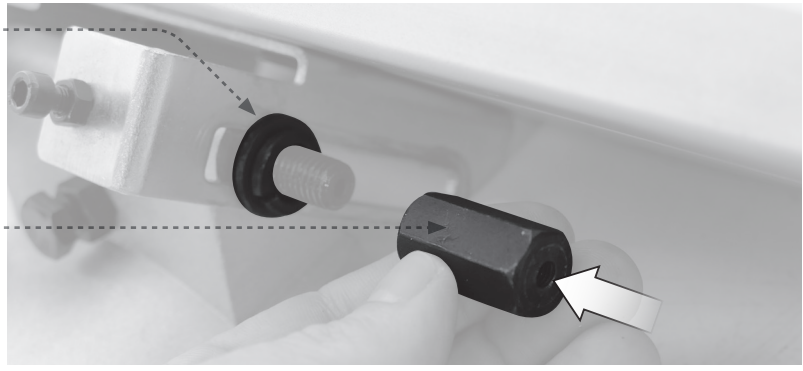

04



12 C

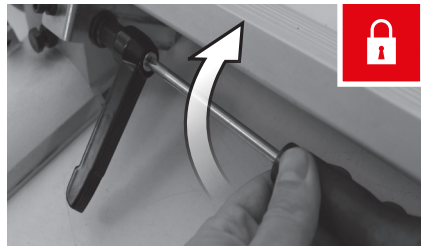
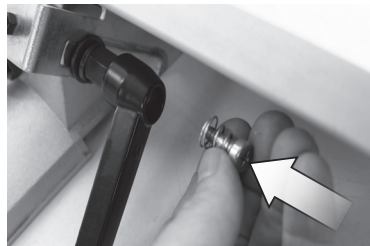



D

Assemblage de la machine *Machine assembly*



Montage du guide

Gids montage
Montaje de guía
Montagem de guia
Montaggio guida
Guide assembly

01

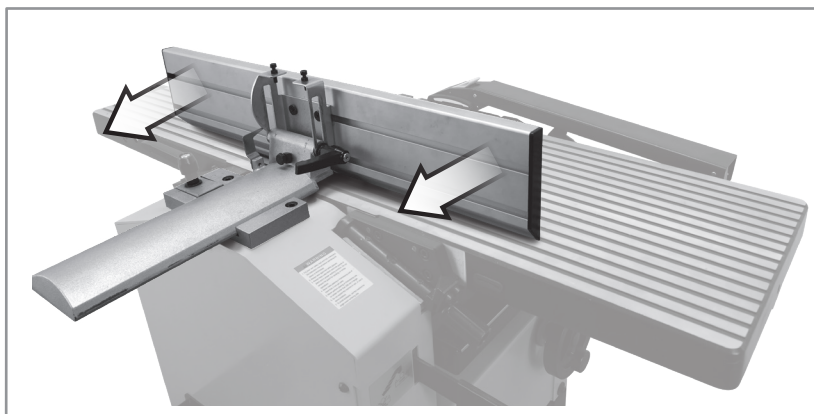
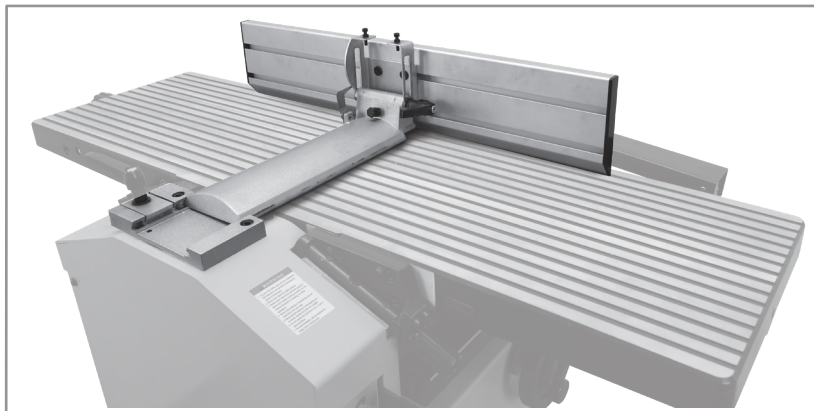
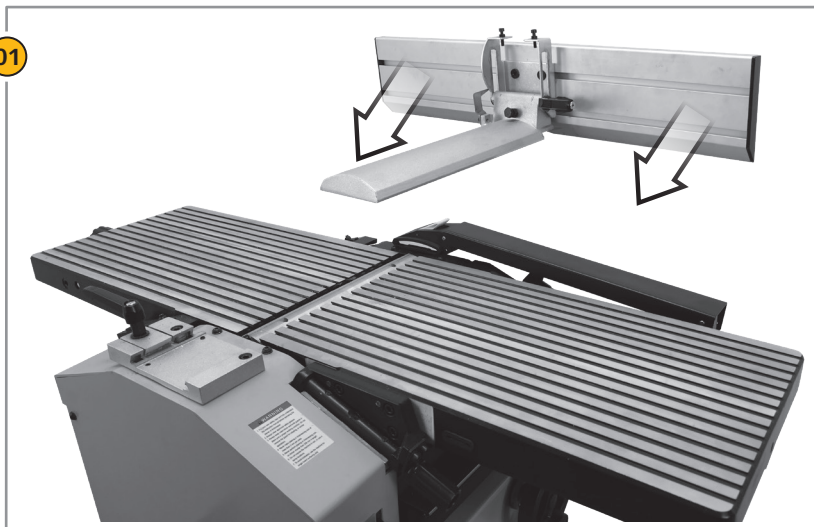



D

Assemblage de la machine Machine assembly



Montage du guide

Gids montage
Montaje de guía
Montagem de guia
Montaggio guida
Guide assembly

02

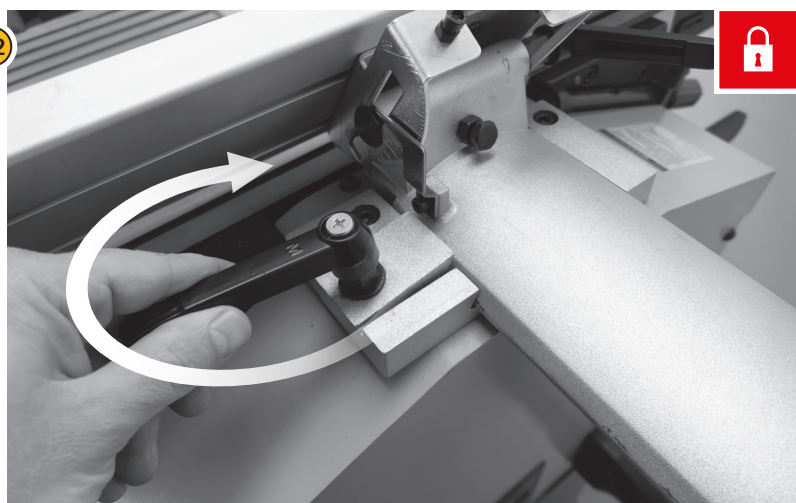

Montage du Protege lame

Montage van de beschermkap
Montaje de la protección de la hoja
Montagem da proteção da lâmina
Montaggio della protezione della lama
Assembly of the blade guard

01

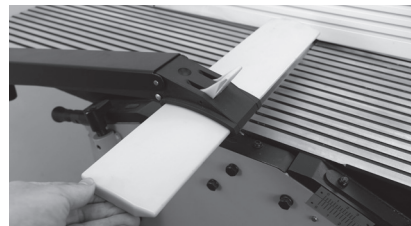
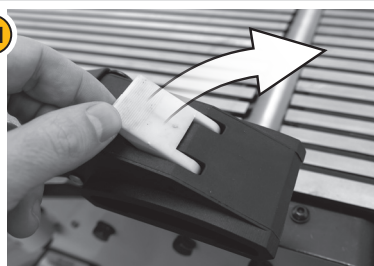

08





D

Assemblage de la machine Machine assembly



Montage du sac

Tas montage
Montaje de bolsa
Montagem de bolsa
Assemblaggio della borsa
Bag assembly



21

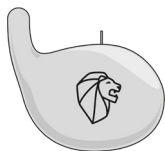

19 a



19 b

01

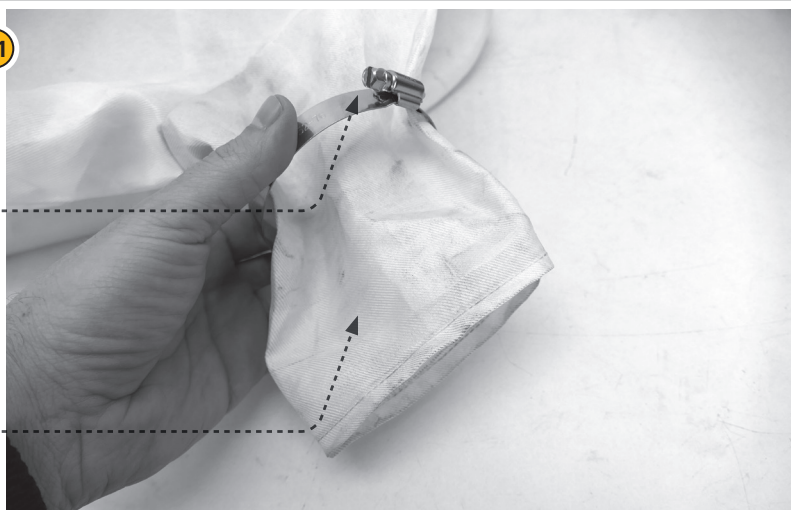

02



03





D

Assemblage de la machine Machine assembly



Montage du carter d'aspiration

De aanzuigbehuizing
monteren
Montaje de la carcasa
de succión
Montagem da caixa de
sucção
Montaggio della cassa
di aspirazione
Assembling the suction
casing

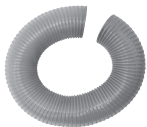

16



06



21

01

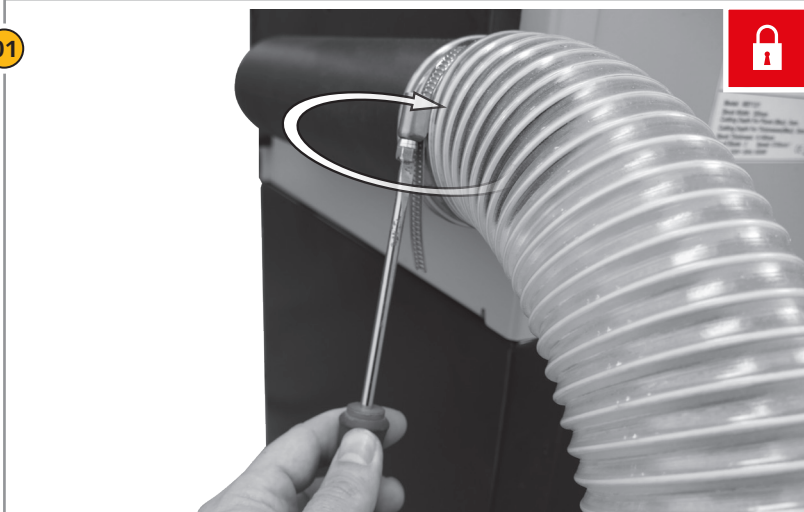

02

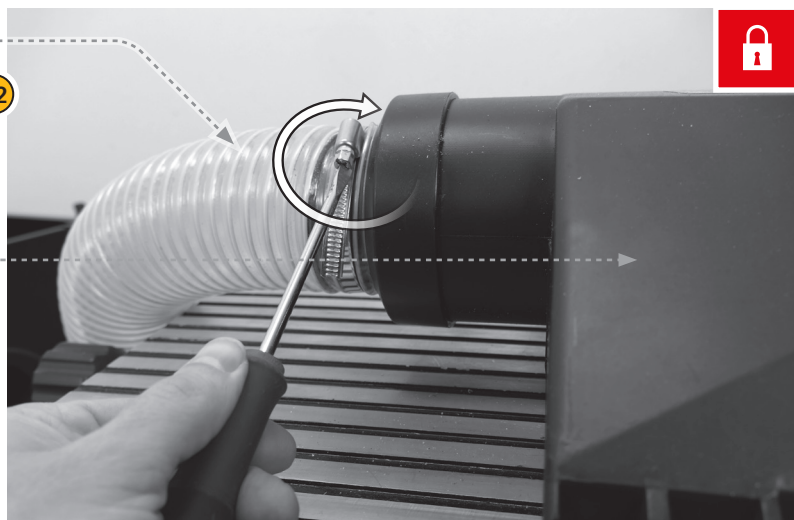



E

Utilisation de la machine

Machine use



Fonction Rabot

Schaaf functie
Función cepilladora
Função Planer
Funzione pialla
Planer function



01



Pour utiliser la fonction Rabot, vous devez retirer le guide de dégauchissage (procéder dans le sens inverse des instructions page 18-19)

Om de schaaf functie te gebruiken, moet u de schaa fgeleider verwijderen (ga in omgekeerde volgorde te werk als de instructies op pagina 18-19)

Para utilizar la función de cepillado, debe retirar la guía de cepillado (proceda en orden inverso a las instrucciones de la página 18-19)

Para usar a função de plaina, você deve remover a guia de aplainamento (proceda na ordem inversa das instruções na página 18-19)

Per utilizzare la funzione pialla è necessario rimuovere la guida di piallatura (procedere in ordine inverso alle istruzioni a pag. 18-19)

To use the planer function, you must remove the planing guide (proceed in reverse order to the instructions on page 18-19)

02

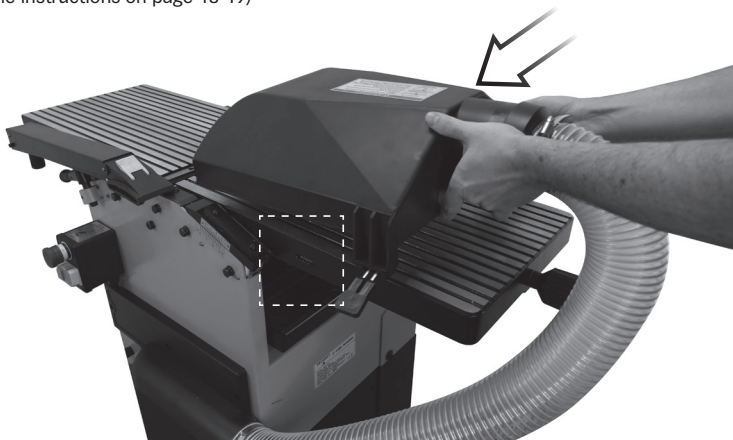

Les contacteurs de sécurité s'insèrent dans les fentes sur le coté de la table :

De veiligheidsschakelaars passen in de sleuven aan de zijkant van de tafel:

Los interruptores de seguridad encajan en las ranuras del lateral de la mesa:

Os interruptores de segurança se encaixam nos slots na lateral da mesa:

Gli interruttori di sicurezza si inseriscono nelle fessure sul lato del tavolo:

The safety switches fit into the slots on the side of the table:

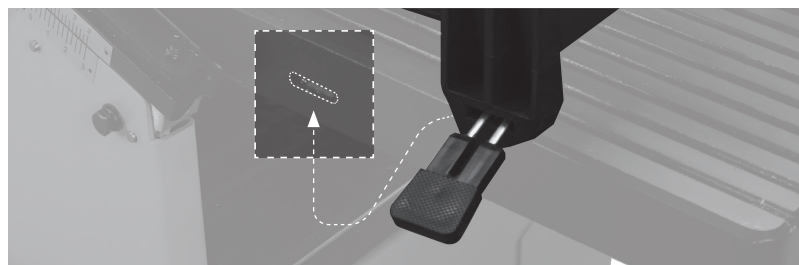



E

Utilisation de la machine

Machine use



Fonction Rabot

Schaaffunctie
Función cepilladora
Função Planar
Funzione pialla
Planer function

Système d'aspiration des poussières

Stofafzuiging
Sistema de extracção de poeiras
Sistema de extracción de polvo
Sistema di estrazione della polvere
Dust extraction system

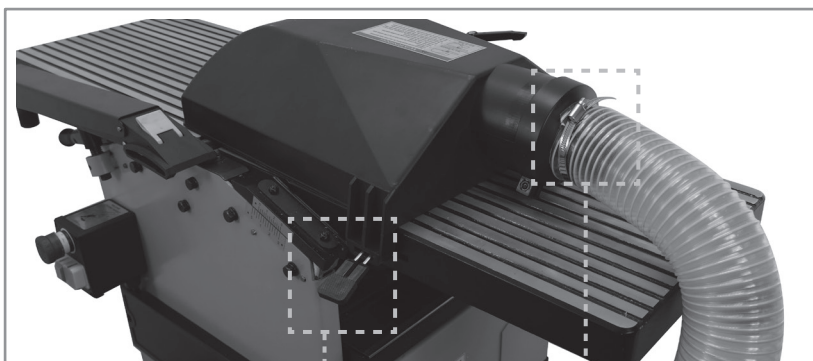

03

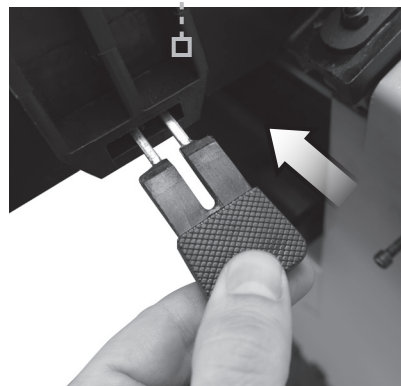
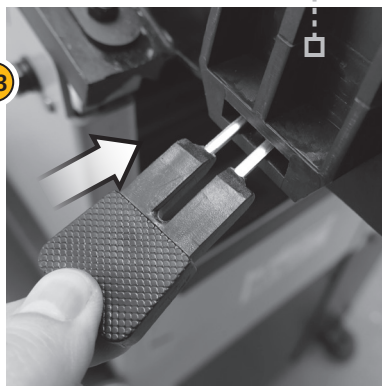

Contacteurs de sécurité : la machine ne démarrera pas si les deux dispositifs ne sont pas correctement verrouillés

Veiligheidsschakelaars: de machine start niet als de twee apparaten niet correct zijn vergrendeld

Interruptores de seguridad: la máquina no arrancará si los dos dispositivos no están correctamente bloqueados

Chaves de segurança: a máquina não iniciará se os dois dispositivos não estiverem bloqueados corretamente

Interruttori di sicurezza: la macchina non si avvia se i due dispositivi non sono correttamente bloccati

Safety switches: the machine will not start if the two devices are not correctly locked





E

Utilisation de la machine

Machine use



Fonction Rabot

Schaaf functie
Función cepilladora
Função Planer
Funzione pialla
Planer function

ON

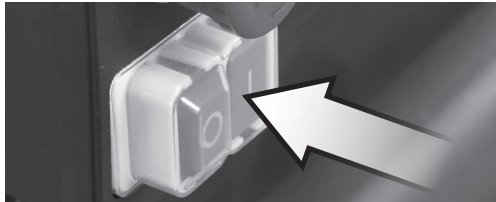
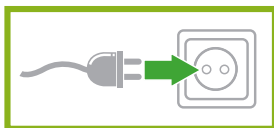

01

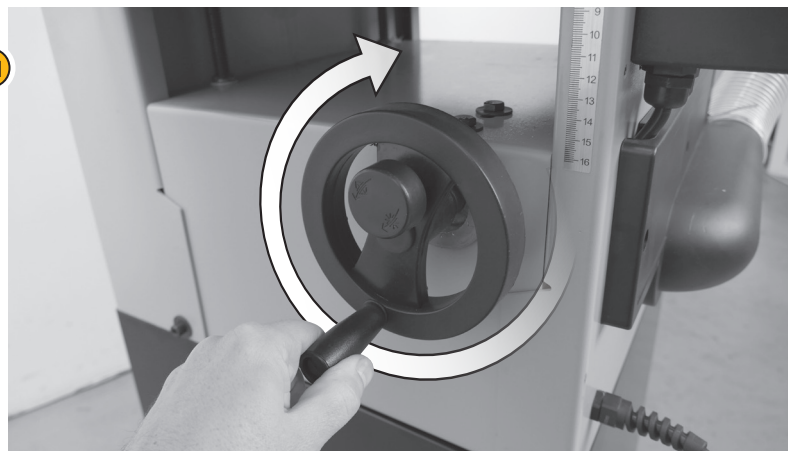

Profondeur de passe : 2 mm maximum !

Snijdiepte: maximaal 2 mm!
Profundidad de corte: 2 mm como máximo.
Profundidade de corte: 2 mm no máximo!
Profondità di taglio: 2 mm massimo!
Depth of cut: 2 mm maximum!



02

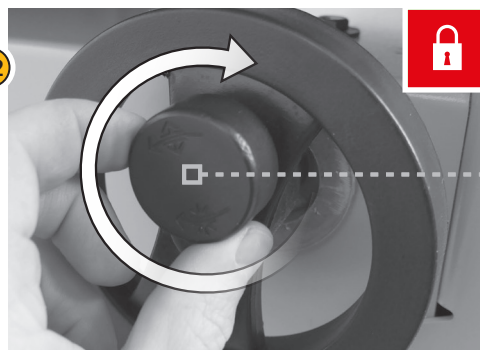

Verrouillage de la table

De tafel op slot doen
Bloquear la mesa
Travando a mesa
Bloccare il tavolo
Locking the table



E

Utilisation de la machine

Machine use



03

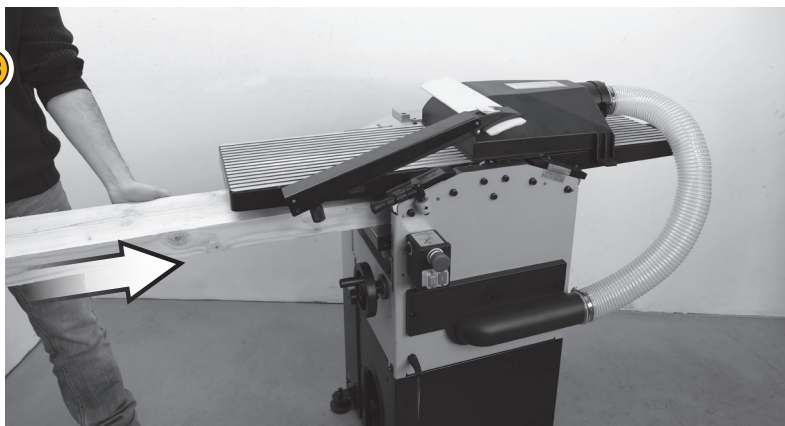

Placer votre pièce de bois sur le plateau, puis manoeuvrer le levier d'entraînement comme montré ci dessous :

Plaats uw stuk hout op het bord en bedien vervolgens de rijhendel zoals hieronder weergegeven: Coloque su trozo de madera en la tabla, luego opere la palanca de transmisión como se muestra a continuación:

Coloque seu pedaço de madeira na placa e, em seguida, opere a alavanca de acionamento conforme mostrado abaixo:

Posiziona il tuo pezzo di legno sulla tavola, quindi aziona la leva di azionamento di seguito:

Place your piece of wood on the board, then operate the drive lever as shown below:

Système d'entraînement automatique

Automatisch aandrijfsysteem
Sistema de accionamiento automático
Sistema de acionamento automático
Sistema di azionamento automatico
Automatic drive system

04



**1 : Relever le levier
2 : pousser le levier vers l'avant
3 : abaisser le levier**

1: Breng de hendel omhoog
2: duw de hendel naar voren
3: laat de hendel zakken

1: levante la palanca
2: empujar la palanca hacia adelante
3: baja la palanca

1: Levante a alavanca
2: empurre a alavanca para frente
3: abaixe a alavanca

1: Alza la leva
2: spingere la leva in avanti
3: abbassare la leva

1: Raise the lever
2: push the lever forward
3: lower the lever

**E**

Utilisation de la machine

Machine use

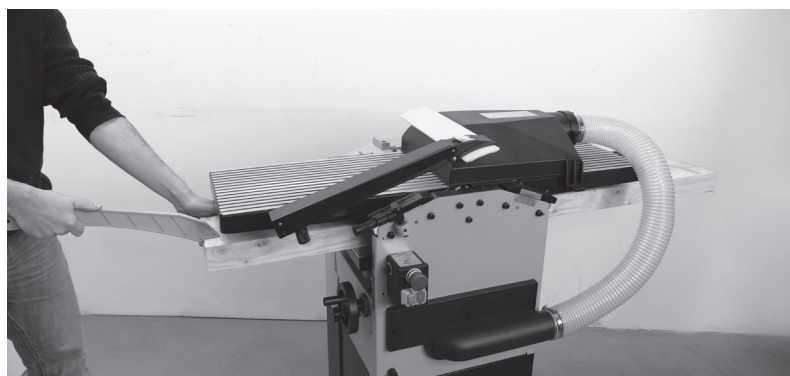
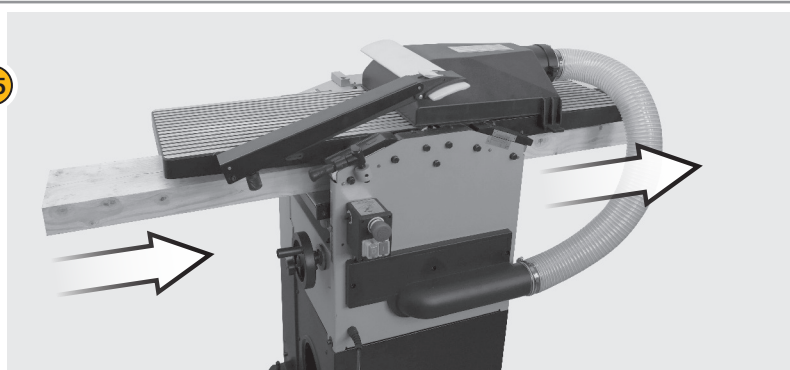
**05****22**

Une fois la pièce entraînée dans la machine, se positionner à la sortie afin de la réceptionner. si celle-ci ne venait pas, tirer la pièce à la main. Arrêter la machine après réception.

Nadat het onderdeel in de machine is getrokken, gaat u bij de uitgang staan om het in ontvangst te nemen. als het niet komt, trek dan met de hand aan het onderdeel. Stop de machine na ontvangst.

Una vez que la pieza ha sido introducida en la máquina, colóquese en la salida para recibirla. si no sale, tire de la pieza con la mano. Detenga la máquina después de recibirla.

Depois de puxada a peça para a máquina, posicione-se na saída para recebê-la. se não vier, puxe a peça com a mão. Pare a máquina após o recebimento.

Una volta che il pezzo è stato trascinato nella macchina, posizionarsi all'uscita per riceverlo. se non arriva, tirare la parte a mano. Arrestare la macchina dopo la ricezione.

Once the part has been drawn into the machine, position yourself at the exit in order to receive it. if it does not come, pull the part by hand. Stop the machine after receipt.

06



E

Utilisation de la machine

Machine use



Toujours alimenter la machine avec la partie la plus épaisse de la pièce à travailler en premier, ceci afin d'éviter un blocage de la machine !

Voer de machine altijd eerst met het dikste deel, om blokkering van de machine te voorkomen!
¡Alimente siempre la máquina con la parte más gruesa primero, para evitar bloquear la máquina!
¡Alimentare sempre la macchina con la parte più spessa per prima, per evitare di bloccare la macchina!

Always feed the machine with the thickest part first, in order to avoid blocking the machine!

07



Arrêt d'urgence :
interrupteur coup de poing

Noodstop :
paddenstoel hoofd schakelaar
Parada de emergencia :
interruptor de cabeza de seta
Parada de emergência :
interruptor de cabeça de cogumelo
Arresto di emergenza :
interruttore a fungo
Emergency stop :
kill switch

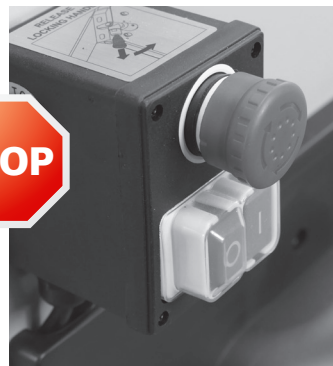

Réarmement
herbewapening
rearme
rearmamento
riarmo
rearmament



**E**

Utilisation de la machine

Machine use

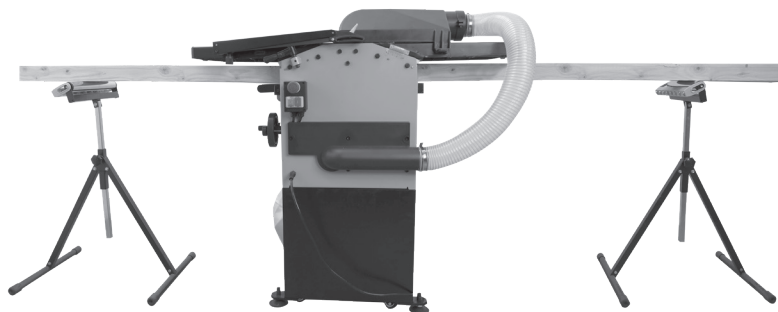

Pour le rabotage de grandes planches, il est recommandé d'utiliser des servantes d'atelier à roulement : risque de rebond de la pièce et de renversement de la machine.

Voor het schaven van grote planken wordt het gebruik van werkplaatswagens met rollen aanbevolen: risico dat het werkstuk terugkaatst en de machine kantelt.

Para el cepillado de tablas de gran tamaño, se recomienda utilizar carros de taller de rodillos: riesgo de rebote de la pieza y vuelco de la máquina.

Para aplainar pranchas grandes, recomenda-se a utilização de carrinhos de oficina com rolos: risco de rebatimento da peça e tombamento da máquina.

Per la piallatura di tavole di grandi dimensioni si consiglia l'utilizzo di carrelli da officina a rulli: rischio di rimbalzo del pezzo e ribaltamento della macchina.

For planing large boards, it is recommended to use roller workshop trolleys: risk of the workpiece rebounding and the machine overturning.

Fonction Dégauchisseur

Jointer-functie:
Función ensambladora
Função de junção
Funzione Jointer
Jointer function

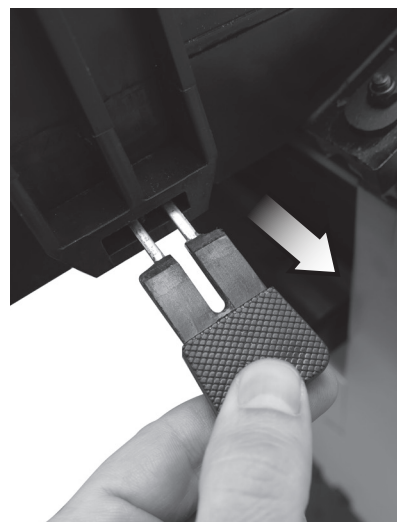
**01**

**E**

Utilisation de la machine

Machine use



Pour utiliser la fonction Dégauchisseuse, vous devez remettre le guide de dégauchissage (voir page 18-19)

Om de verbindingfunctie te gebruiken, moet u de verbindingseleider vervangen (zie pagina 18-19)

Para utilizar la función ensambladora, debe reemplazar la guía ensambladora (consulte la página 18-19)

Para usar a função de junta, você deve substituir a guia de junta (consulte a página 18-19)

Per utilizzare la funzione jointer, è necessario sostituire la guida jointer (vedi pagina 18-19)

To use the jointer function, you must replace the jointer guide (see page 18-19)

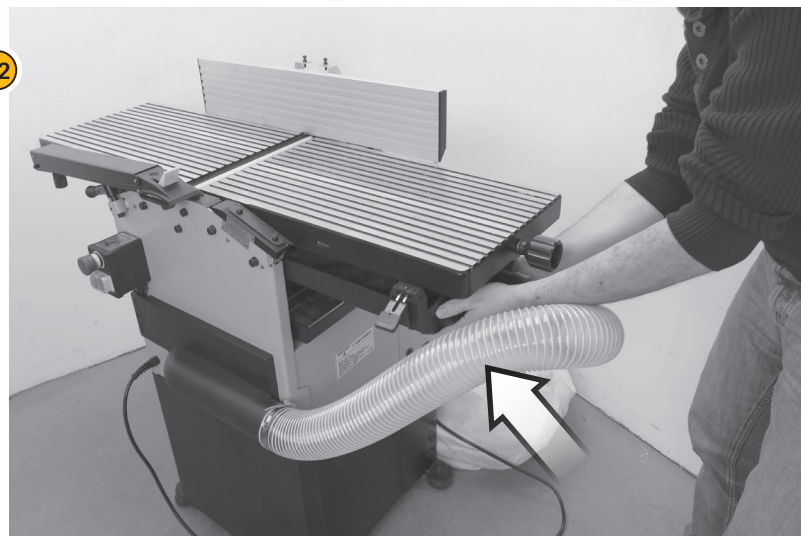
**02**



E

Utilisation de la machine Machine use



Fonction Dégauchiseur

Jointer-functie:
Função ensambladora
Função de junção
Funzione Jointer
Jointer function

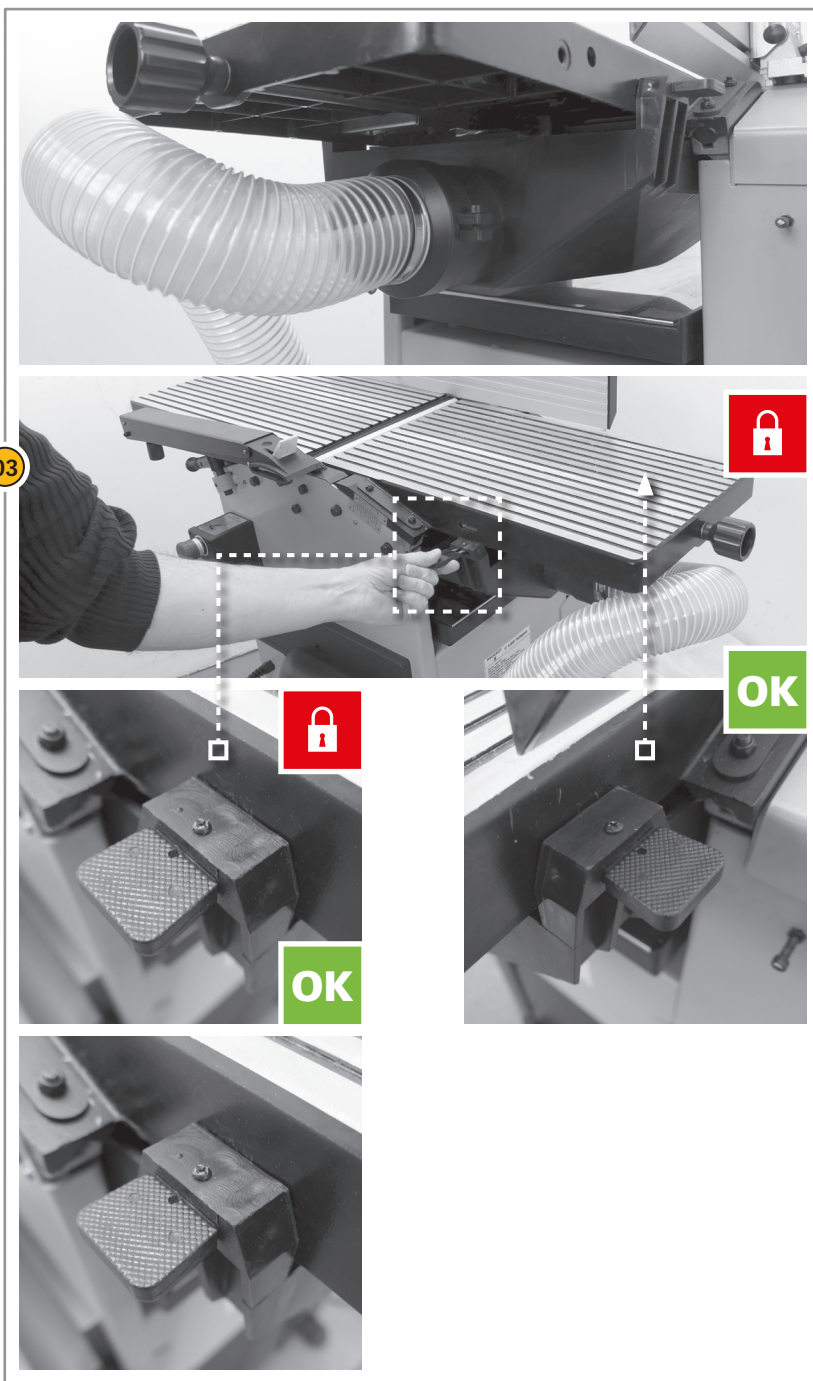

03



**E**

Utilisation de la machine

Machine use

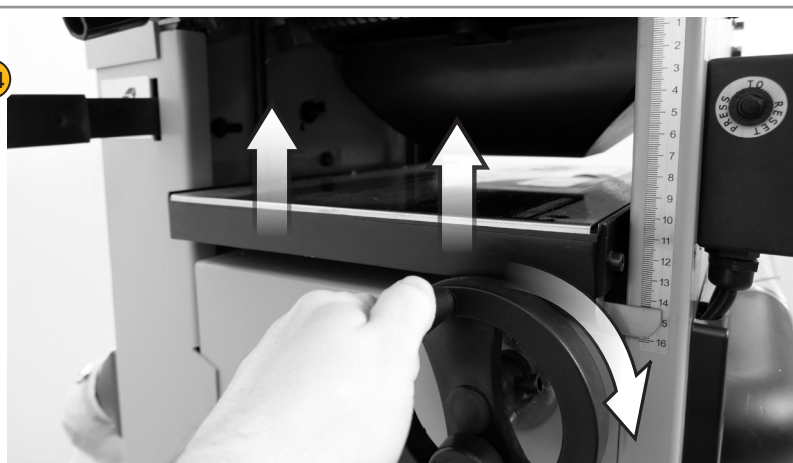
**04**

Remonter la table de rabotage de façon à ce qu'elle vienne au contact du carter d'aspiration afin de le bloquer, puis verrouiller la table

Zet de schaaf tafel weer in elkaar zodat deze in contact komt met de aanzuigbehuizing om deze te blokkeren en vervolgens de tafel

Vuelva a montar la mesa de cepillado para que entre en contacto con la carcasa de succión para bloquearla, luego bloquee la mesa

Remonte a mesa de aplainamento de modo que ela entre em contato com o invólucro de sucção a fim de bloqueá-la e, em seguida, trave a mesa

Rimontare il piano di piallatura in modo che venga a contatto con il corpo aspirante per bloccarlo, quindi bloccare il piano

Reassemble the planing table so that it comes into contact with the suction casing in order to block it, then lock the table

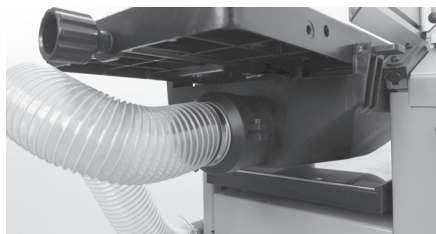
05



E

Utilisation de la machine

Machine use



Fonction Dégauchisseur

Jointer-functie:
Función ensambladora
Função de junção
Funzione Jointer
Jointer function

06

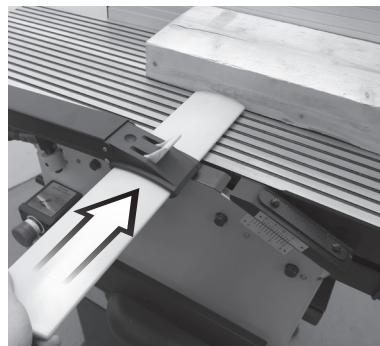
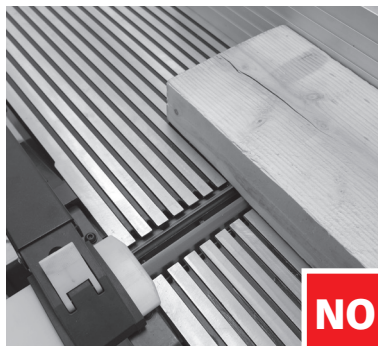
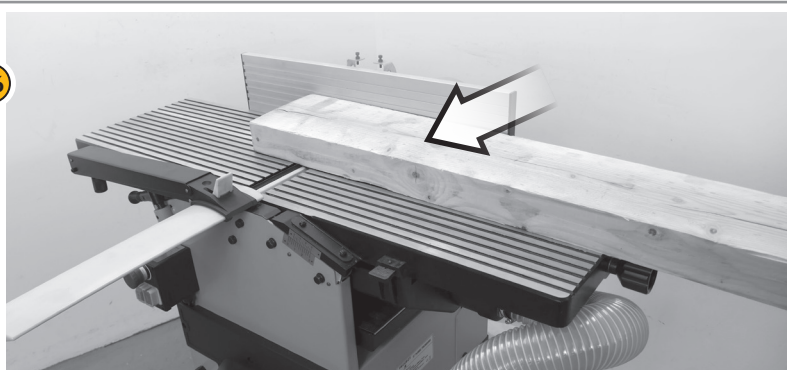

Ne pas travailler la pièce sans la protection de lames !

Weet u het stuk hout niet werken zonder het onderhoud arm !
No trabaje el trozo de madera sin el brazo de mantenimiento !
Não trabalhe o pedaço de madeira sem o braço de manutenção !
Non lavorare il pezzo di legno senza il braccio di manutenzione !
Do not work the piece of wood without holding arm !

Lors du dégauchissage de la pièce, plaquer le bras de maintien sur la pièce à travailler, (ou si besoin sur la zone où les fers sont visibles) de façon à maintenir celle-ci sur la table, et protéger les mains du cylindre porte lames (au dessus, ou sur le coté)

Plaats bij het uitlijnen van het onderdeel de houdarm op het werkstuk (of indien nodig op het gebied waar de ijzers zichtbaar zijn) om het op de tafel te houden en bescherm de handen van de mescilinder (boven of aan de zijkant) Al alinear la pieza, coloque el brazo de sujeción en la pieza de trabajo (o si es necesario en el área donde los hierros son visibles) para mantenerlo sobre la mesa, y proteger las manos del cilindro de la hoja (arriba o al costado.) Ao alinhar a peça, coloque o braço de sustentação na peça de trabalho (ou se necessário na área onde os ferros são visíveis) de modo a mantê-la sobre a mesa e proteger as mãos do cilindro da lâmina (acima ou na lateral) Quando si allinea il pezzo, posizionare il braccio di presa sul pezzo, (o se necessario nella zona in cui sono visibili i ferri) in modo da tenerlo sul tavolo e proteggere le mani del cilindro lame (sopra, o di lato) When aligning the part, place the holding arm on the workpiece, (or if necessary on the area where the irons are visible) so as to keep it on the table, and protect the hands of the blade cylinder (above, or on the side)

**E**

Utilisation de la machine

Machine use

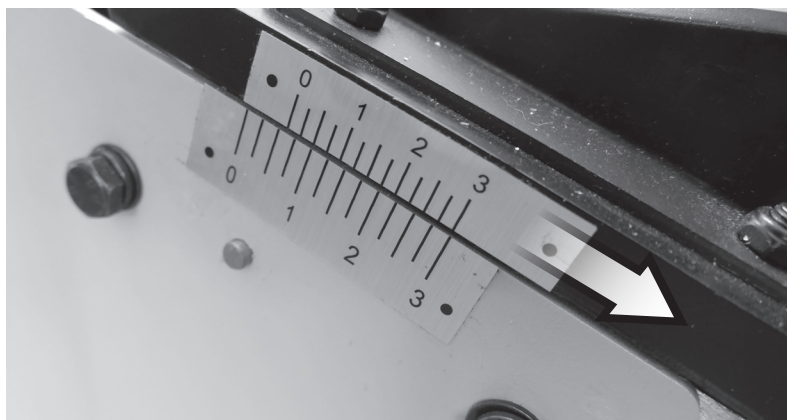
**07**

Réglage de la passe de 0 à 3 mm MAXI
Aanpassing van de pas van 0 tot 3 mm MAXI
Ajuste del paso de 0 a 3 mm MAXI
Ajuste do passe de 0 a 3 mm MAXI
Regolazione del passo da 0 a 3 mm MAXI
Adjustment of the pass from 0 to 3 mm MAXI

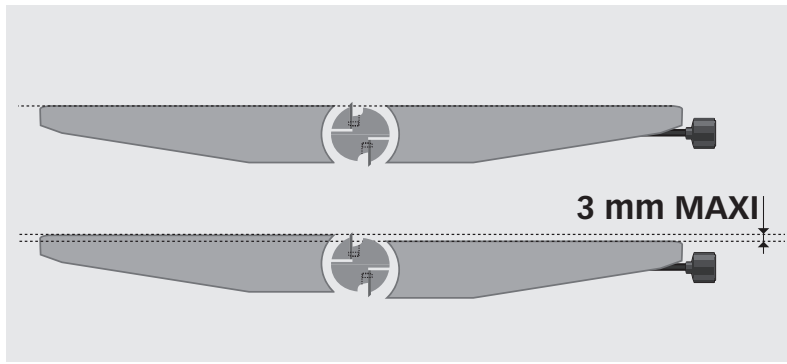

**E**

Utilisation de la machine

Machine use

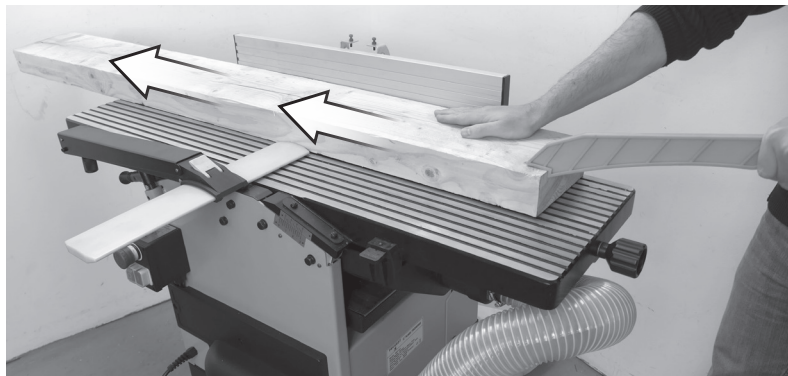
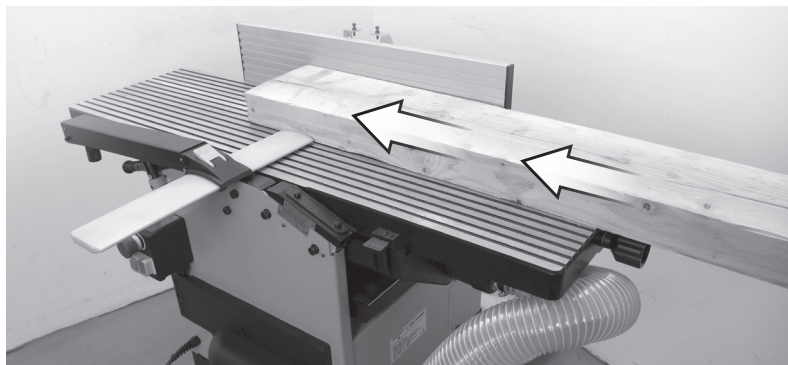
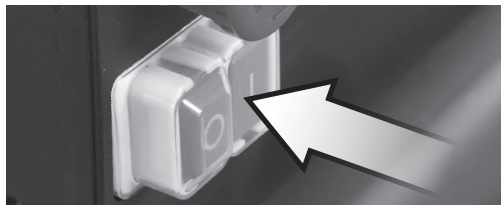
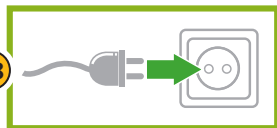
**08**

Pour le dégauchissage de grandes planches, il est recommandé d'utiliser des servantes d'atelier à rouleau : risque de rebond de la pièce.

Voor het schaven van grote planken wordt het gebruik van werkplaatswagens met rollen aanbevolen: risico op terugkaatsen van het onderdeel.

Para el cepillado de tablas de gran tamaño, se recomienda utilizar carros de taller con ruedas: riesgo de rebote de la pieza.

Para aplainar pranchas grandes, recomenda-se a utilização de carrinhos de oficina com rolos: risco de rebatimento da peça.

Per la piallatura di tavole di grandi dimensioni si consiglia l'utilizzo di carrelli da officina a rulli: rischio di rimbalzo del pezzo.

For planing large boards, it is recommended to use roller workshop trolleys: risk of the workpiece rebounding.





E

Utilisation de la machine

Machine use



09

Protection thermique manuelle

Handmatige thermische beveiliging
 Protección térmica manual
 Protezione termica manuale
 Proteção térmica manual
 Manual Thermal protection

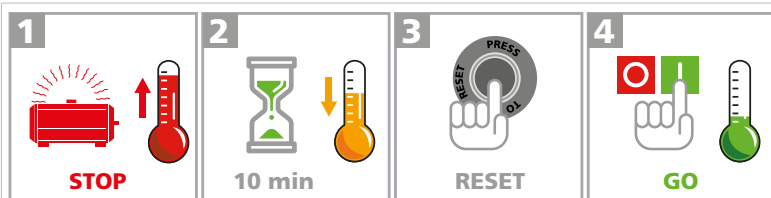
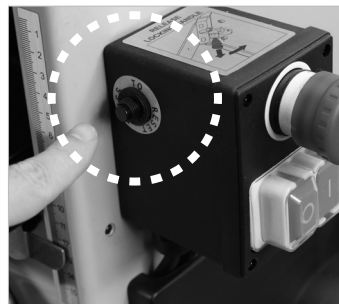

FR Cette machine est équipée d'une protection thermique manuelle. En cas de surchauffe du moteur celui-ci s'arrête automatiquement (1). Pour le redémarrer, il faut attendre qu'il refroidisse (2), enclencher le bouton de réarmement (3) et rallumer le moteur (4).

EN This machine is equipped with manual thermal protection. In case of overheating of the engine it will stop automatically (1). To restart it, wait until it can cool down (2), engage the reset button (3) and restart the engine (4).

ES Esta máquina está equipada con protección térmica manual. En caso de sobrecalentamiento del motor, se detendrá automáticamente (1). Para reiniciarlo, espere hasta que se enfrie (2), active el botón de reinicio (3) y reinicie el motor (4).

IT Questa macchina è dotata di protezione termica manuale. In caso di surriscaldamento del motore si arresterà automaticamente (1). Per riavviarlo, attendere che si raffreddi (2), inserire il pulsante di ripristino (3) e riavviare il motore (4).

PT Esta máquina está equipada com proteção térmica manual. Em caso de superaquecimento do motor, ele pára automaticamente (1). Para reiniciá-lo, aguarde até que ele esfrie (2), pressione o botão de reinicialização (3) e reinicie o motor (4).

NL Deze machine is uitgerust met handmatige thermische beveiliging. Bij oververhitting van de motor zal deze automatisch stoppen (1). Wacht om hem te herstarten tot hij kan afkoelen (2), druk op de resetknop (3) en start de motor opnieuw (4).



E

Utilisation de la machine Machine use



Utilisation du guide

De gids gebruiken
Usando la guía
Usando o guia
Using the guide

01

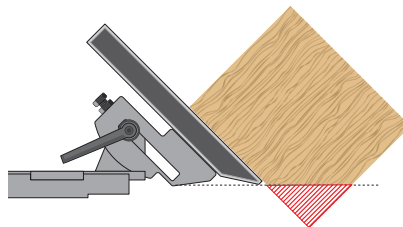
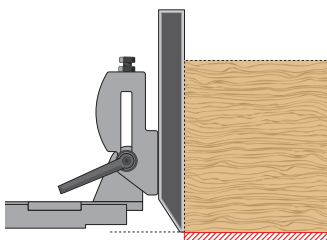
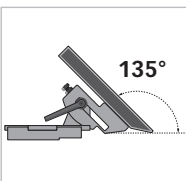
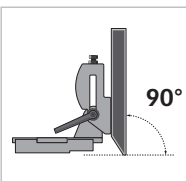
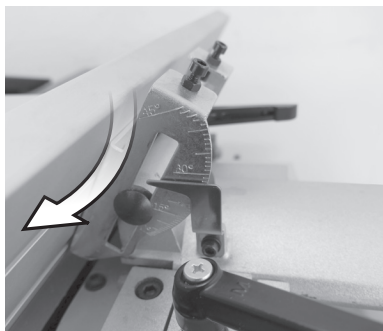



F

Remplacement des consommables

Spare parts replacement

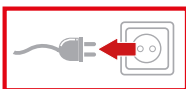

Avant toute opération sur la maintenance de la machine, la débrancher du secteur IMPÉRATIVEMENT !

Voor elke operatie: op onderhoud van de automaat, haal de stekker uit het stopcontact **VERPLICHT!**

Antes de cualquier operación en mantenimiento de la máquina, desconectarlo de la red **¡IMPERATIVAMENTE!**

Antes de qualquer operação em manutenção da máquina, desligue-o da rede **IMPERATIVAMENTE!**

Prima di qualsiasi operazione in manutenzione della macchina, scollegarlo dalla rete **IMPERATIVAMENTE!**

Before any operation on maintenance of the machine, disconnect it from the mains **IMPERATIVELY!**



01

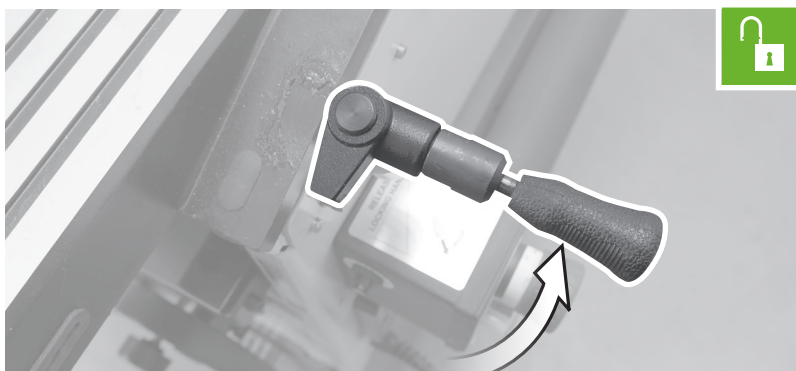
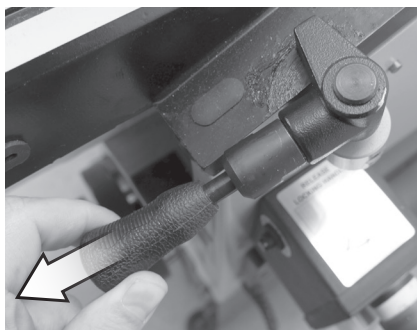

Tirer sur la poignée pour déverrouiller, puis tourner d'un quart de tour vers la droite. Soulever la table vers l'arrière, jusqu'à ce que celle-ci se verrouille automatiquement.

Trek aan de hendel om te ontgrendelen en draai vervolgens een kwartslag naar rechts. Til de tafel terug totdat deze automatisch vergrendelt.

Jale la manija para desbloquear, luego gire un cuarto de vuelta a la derecha.

Levante a mesa hacia atrás hasta que se bloquee automáticamente.

Puxe a alça para destravar e, em seguida, gire um quarto de volta para a direita.

Levante a mesa até que ela trave automaticamente.

Tirare la maniglia per sbloccare, quindi girare di un quarto di giro a destra.

Sollevare indietro il tavolo finché non si blocca automaticamente.

Pull on the handle to unlock, then turn a quarter turn to the right.

Lift the table back until it locks automatically.

02

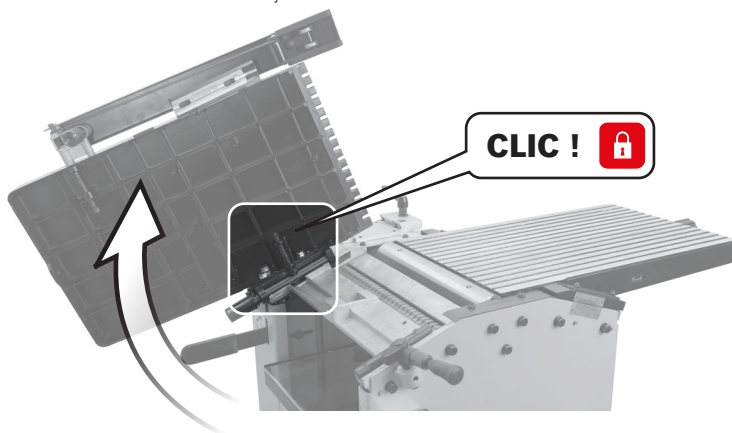



F

Remplacement des consommables

Spare parts replacement

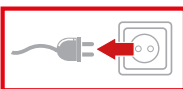

Avant toute opération sur la maintenance de la machine, la débrancher du secteur IMPÉRATIVEMENT !

Voor elke operatie: op onderhoud van de automaat, haal de stekker uit het stopcontact VERPLICHT!

Antes de cualquier operación en mantenimiento de la máquina, desconectarlo de la red ¡IMPERATIVAMENTE!

Antes de qualquer operação em manutenção da máquina, desligue-o da rede IMPERATIVAMENTE!

Prima di qualsiasi operazione in manutenzione della macchina, scollegarlo dalla rete IMPERATIVAMENTE!

Before any operation on maintenance of the machine, disconnect it from the mains IMPERATIVELY!



Pour rabattre la table, tirer sur le loquet de verrouillage et ramener la table vers l'avant. **NE PAS FORCER !**

Para plegar la mesa, tire del pestillo de bloqueo y tire de la mesa hacia adelante. **¡NO FORZAR!**

Para plegar la mesa, tire del pestillo de bloqueo y tire de la mesa hacia adelante. **¡NO FORZAR!**

Para dobrar a mesa, puxe a trava de bloqueio e puxe a mesa para frente. **NÃO FORÇE!**

Per piegare il tavolo, tirare il fermo di blocco e tirare il tavolo in avanti. **NON FORZARE!**

To fold down the table, pull the locking latch and bring the table forward. **DO NOT FORCE!**

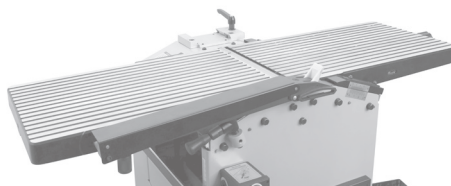
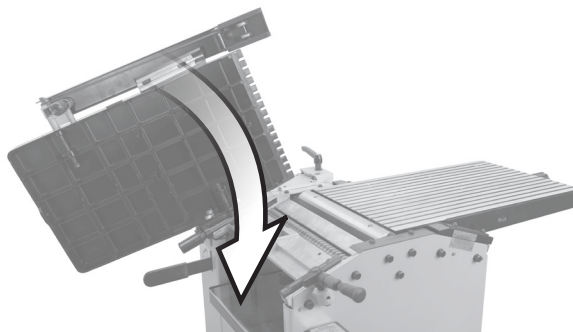



F

Remplacement des consommables *Spare parts replacement*

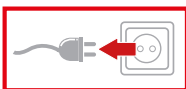

Avant toute opération sur la maintenance de la machine, la débrancher du secteur IMPÉRATIVEMENT !

Voor elke operatie: op onderhoud van de automaat, haal de stekker uit het stopcontact **VERPLICHT!**

Antes de cualquier operación en mantenimiento de la máquina, desconectarlo de la red **¡IMPERATIVAMENTE!**

Antes de qualquer operação em manutenção da máquina, desligue-o da rede **IMPERATIVAMENTE!**

Prima di qualsiasi operazione in manutenzione della macchina, scollegarlo dalla rete **IMPERATIVAMENTE!**

Before any operation on maintenance of the machine, disconnect it from the mains **IMPERATIVELY!**



03

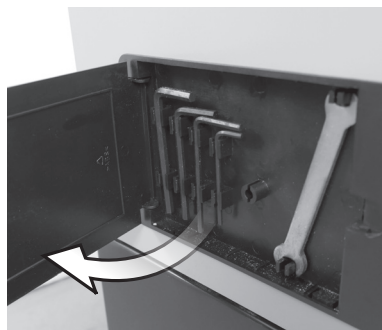

04

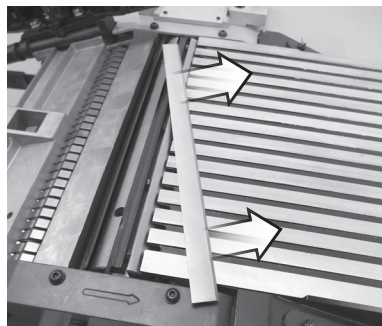

x5

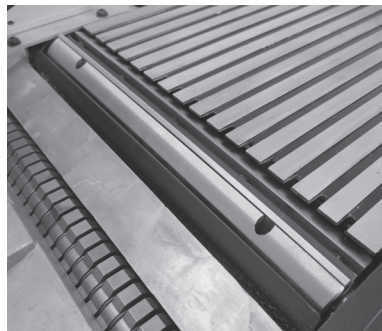
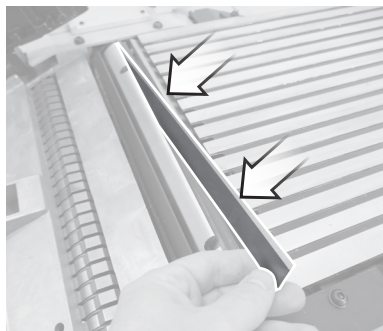

Option - Opcional - Opzione - Opção - Optie - Option

805706:

Jeu de 2 fers

Set van 2 schaafmessen
Juego de 2 cuchillas cepilladoras
Conjunto de 2 lâminas de plaina
Set di 2 lame per pialla
Set of 2 planer blades

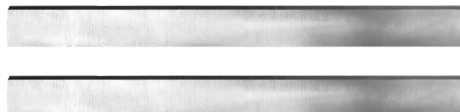



F

Remplacement des consommables

Spare parts replacement

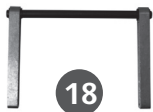

05

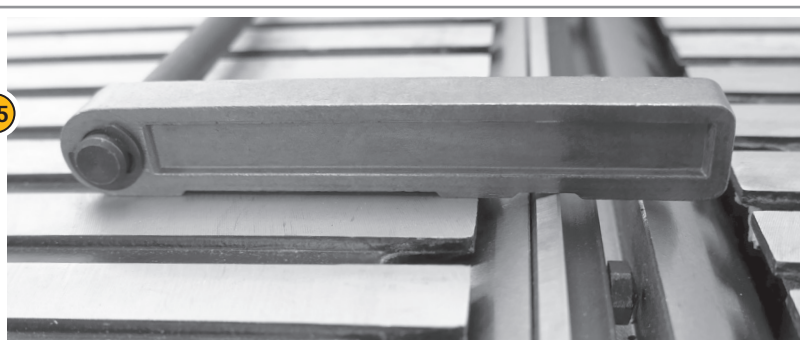

Méthode n°1

- Methode # 1
- Método 1
- Método 1
- Metodo n. 1
- Method # 1

Poser l'outil de réglage sur la table fixe; les fers doivent la toucher et le tout doit être parfaitement aligné
 Plaats de strip op de tafel instelling vast de schoenen moet raken en alles moet perfect uitgelijnd worden
 Coloque la tira en el ajuste de la tabla fija los zapatos deben tocar y todo debe estar perfectamente alineado
 Coloque a tira sobre o ajuste da tabela fixa os sapatos devem tocar e tudo deve estar perfeitamente alinhados
 Posizionare la striscia sul tavolo impostazione fissa le scarpe devono toccare e tutto deve essere perfettamente allineato
 Place the tool on the table setting fixed the blades should touch and everything must be perfectly aligned

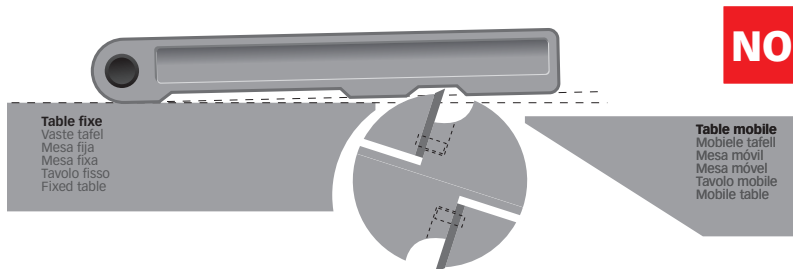
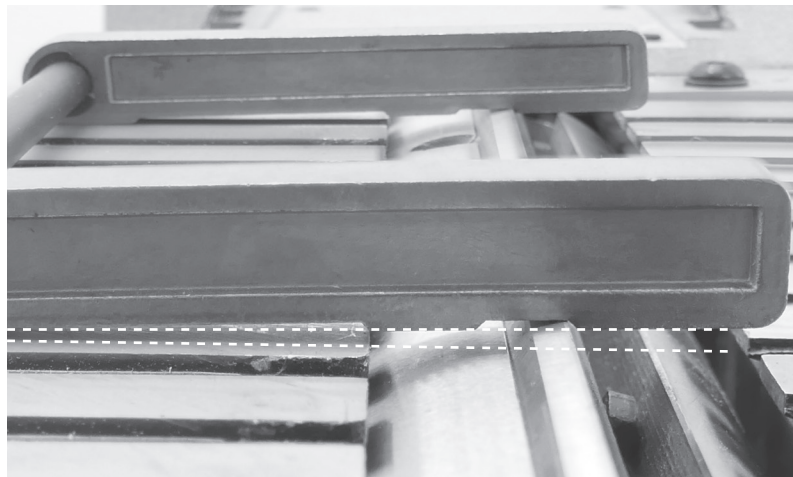

**F**

Remplacement des consommables

Spare parts replacement



Desserer les vis pour faire monter la lame, et inversement.

Draai de schroeven los om het mes omhoog te brengen en vice versa.
Afloje los tornillos para levantar la hoja y viceversa.

Afrouxe os parafusos para levantar a lâmina e vice-versa.
Allentare le viti per sollevare la lama e viceversa.

Loosen the screws to raise the blade, and vice versa.

**OK**

Table fixe
Vaste tafel
Mesa fija
Mesa fixa
Tavolo fisso
Fixed table

Table mobile
Mòbile tafell
Mesa mòvil
Mesa mòvel
Tavolo mòbile
Mobile table

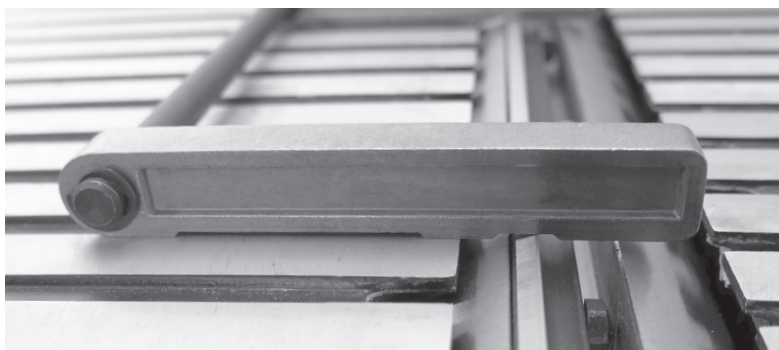
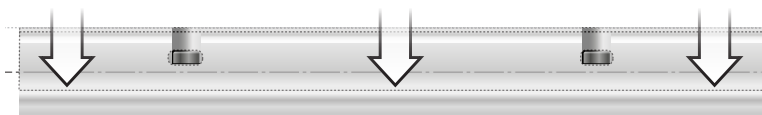
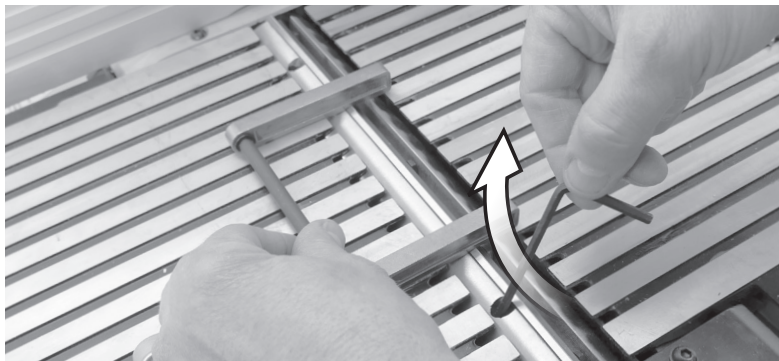

F

Remplacement des consommables

Spare parts replacement



Méthode n°2

Methode # 2
Método 2
Método 2
Metodo n. 2
Method # 2

06



Table fixe

Vaste tafel
Mesa fija
Mesa fija
Tavolo fisso
Fixed table

Table mobile

Mobiele tafell
Mesa móvil
Mesa móvil
Tavolo mobile
Mobile table



Poser un réglett métallique bien droit (non livré) sur la table fixe ; les fers doivent le toucher et le tout doit être parfaitement aligné.

Plaats een rechte metalen regel (niet meegeleverd) op de vaste tafel; de ijzers moeten het aanraken en alles moet perfect uitgelijnd zijn.

Coloque una regla de metal recta (no incluida) en la mesa fija; los hierros deben tocarlo y todo debe estar perfectamente alineado.

Coloque uma régua de metal reta (não fornecida) na mesa fixa; os ferros devem tocá-lo e tudo deve estar perfeitamente alinhado.

Posizionare una regola metallica diritta (non in dotazione) sul tavolo fisso; i ferri devono toccarlo e tutto deve essere perfettamente allineato.

Place a straight metal rule (not supplied) on the fixed table; the irons must touch it and everything must be perfectly aligned.



Répéter l'opération pour l'autre coté du cylindre

Herhaal de handeling voor de andere kant van de cilinder
Repita la operación para el otro lado del cilindro.
Repita a operação para o outro lado do cilindro
Ripetere l'operazione per l'altro lato del cilindro
Repeat the operation for the other side of the cylinder

G

Nettoyage et entretien

Cleaning



Nettoyage

De gids gebruiken
Usando la guía
Usando o guia
Usando la guida
Using the guide

01

Ouverture : voir page 37

Opening : zie pagina 37
Apertura : consulte la página 37
Abertura : ver página 37
Apertura : vedi pagina 37
Opening : see page 37

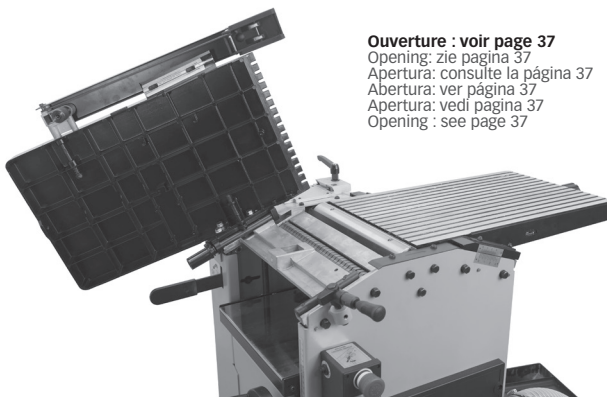



G

Nettoyage et entretien *Cleaning*



Souffler régulièrement les résidus de sciure et copeaux

Blaas regelmatig zaagsel en schaafselresten weg
 Elimine regularmente el aserrín y los residuos de virutas.
 Limpe regularmente resíduos de serragem e aparas
 Soffiare regolarmente i residui di segatura e trucioli
 Regularly blow off sawdust and shavings residues

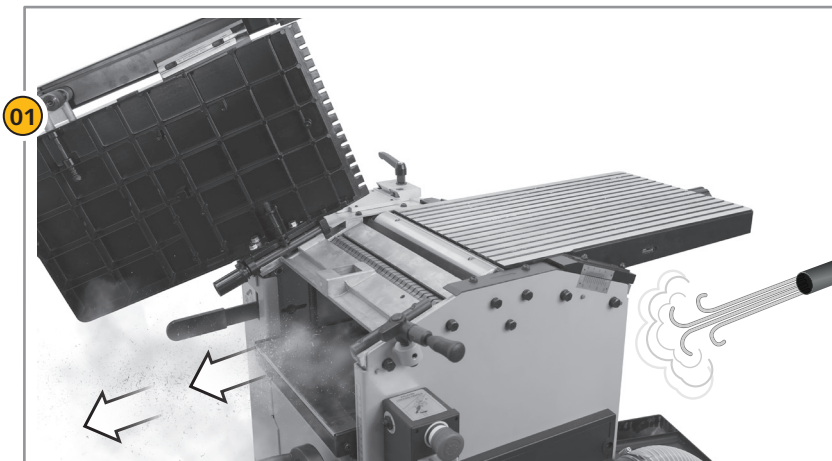

Vider le sac très régulièrement !

Leeg de zak zeer regelmatig!
 ¡Vacíe la bolsa con mucha regularidad!
 Esvazie o saco muito regularmente!
 Svuota la borsa molto regolarmente!
 Empty the bag very regularly!

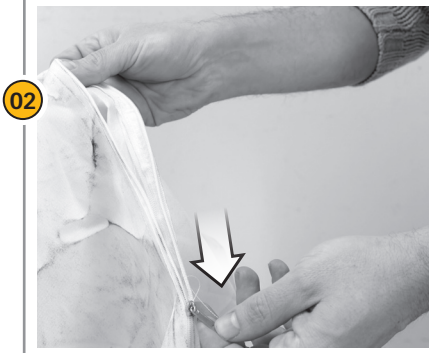

Tension des courroies et graissage des chaînes

Riemspanning en kettingsmering
 Tensión de la correa y lubricación de la cadena.
 Tensão da correia e lubrificação da corrente
 Tensione della cinghia e lubrificazione della catena
 Belt tension and chain lubrication

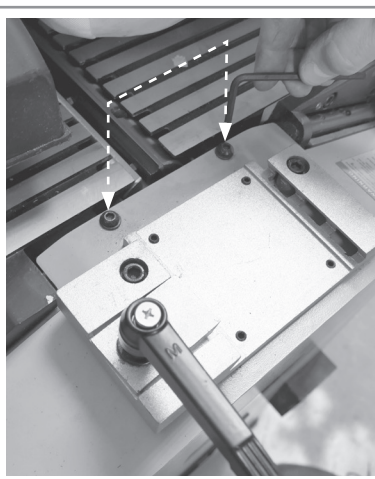
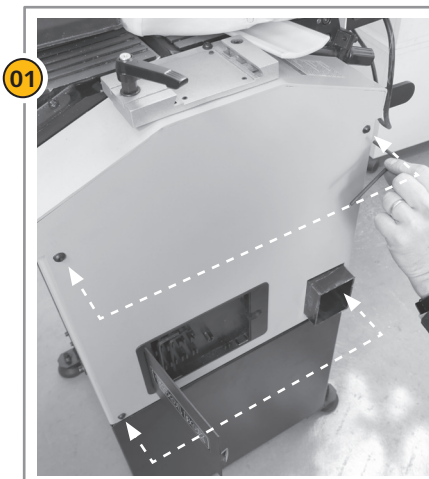

Dévisser les 6 vis

Draai de 6 schroeven los
 Desatornille los 6 tornillos
 Desaparafuse os 6 parafusos
 Svitare le 6 viti
 Unscrew the 6 screws



G

Nettoyage et entretien Cleaning



Tension des courroies et graissage des chaînes

Riemsparing en kettingsmering
Tensión de la correa y lubricación de la cadena.
Tensão da correia e lubrificação da corrente
Tensione della cinghia e lubrificazione della catena
Belt tension and chain lubrication

02

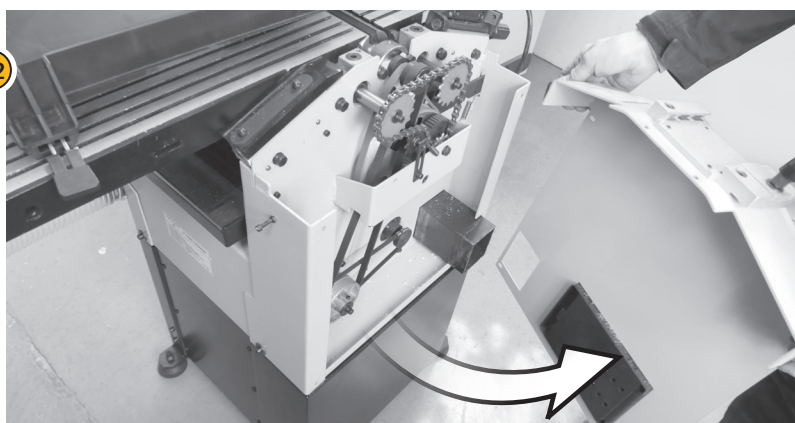

03

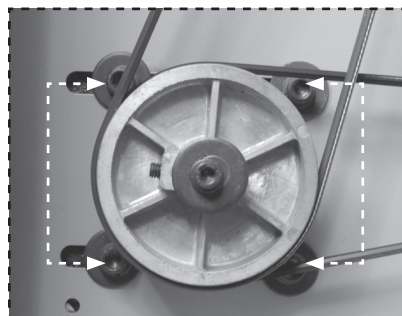

Régler la tension des courroies en déplaçant la position du moteur en agissant sur les 4 vis ci dessus

Pas de spanning van de riemen aan door de positie van de motor te verplaatsen door op de 4 schroeven hierboven te werken

Ajuste la tensión de las correas moviendo la posición del motor actuando sobre los 4 tornillos de arriba

Ajuste a tensão das correias movendo a posição do motor agindo nos 4 parafusos acima

Regolare la tensione delle cinghie spostando la posizione del motore agendo sulle 4 viti sopra

Adjust the tension of the belts by moving the position of the motor by acting on the 4 screws above

04



Graissage

smearing
Lubricación
Lubrificação
Lubrificazione
Lubrication





H

Déplacement de la machine *Moving the machine*

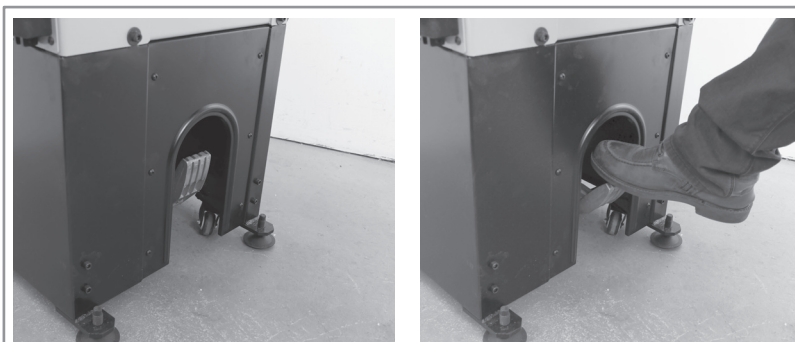

01



93 Kg

02



La machine est aisément déplaçable

De machine is gemakkelijk verplaatsbaar
La máquina se puede mover fácilmente
A máquina é facilmente movível
La macchina è facilmente spostabile
The machine is easily movable





Guide de dépannage

Troubleshooting guide



FR

PROBLÈME	CAUSE	SOLUTION
La machine ne peut pas être allumée	<ul style="list-style-type: none"> Pas d'alimentation électrique Le disjoncteur s'est déclenché 	<ul style="list-style-type: none"> Vérifier l'état du réseau Réenclencher le disjoncteur
La machine s'éteint automatiquement pendant le fonctionnement à vide	<ul style="list-style-type: none"> Pas d'alimentation électrique 	<ul style="list-style-type: none"> Vérifier les fusibles En raison de la protection basse tension intégrée, la machine ne redémarre pas automatiquement. Au retour de la tension, la machine doit être remise en marche (voir page 35)
La machine s'arrête pendant le rabotage	<ul style="list-style-type: none"> La protection contre les surcharges réagit en raison de copeaux émoussés, d'une alimentation trop rapide ou d'un enlèvement de copeaux trop épais. 	<ul style="list-style-type: none"> Avant de poursuivre le travail, remplacez les copeaux ou laissez refroidir le moteur. Réinitialiser la protection contre les surcharges (voir page 35)
Déclenchement de la protection contre les surcharges	<ul style="list-style-type: none"> Trop de copeaux Alimentation trop rapide Couteaux émoussés 	<ul style="list-style-type: none"> Avant de poursuivre le travail, remplacez les copeaux ou laissez refroidir le moteur. Réinitialiser la protection contre les surcharges (voir page 35)
Surface rabotée non lisse	<ul style="list-style-type: none"> Alimentation trop rapide Couteaux émoussés Alimentation irrégulière 	<ul style="list-style-type: none"> Réduire la vitesse d'alimentation Remplacer les copeaux Appliquer une pression constante et réduire l'avance
La vitesse diminue pendant le travail	<ul style="list-style-type: none"> Evacuation des copeaux trop importante 	<ul style="list-style-type: none"> Réduire la hauteur de passe

EN

PROBLEM	CAUSE	SOLUTION
Machine cannot be switched on	<ul style="list-style-type: none"> No power supply Circuit breaker is tripped 	<ul style="list-style-type: none"> Check power supply Reset circuit breaker
Machine switches automatically off during idle run	<ul style="list-style-type: none"> No mains supply 	<ul style="list-style-type: none"> Check fuses Due to the integrated low voltage protection, the machine does not restart automatically. Upon return of the voltage, the machine must be switched on again (see page 35)
Machine stops during planing	<ul style="list-style-type: none"> Overload protection reacts due to blunt knives, infeed too fast, or chip removal too thick 	<ul style="list-style-type: none"> Before work is continued, replace knives or let cool down the motor. Reset the overload protection (see page 35)
Response of the overload protection	<ul style="list-style-type: none"> Too much chip removal Too fast feed Blunt knives 	<ul style="list-style-type: none"> Before work is continued, replace knives or let cool down the motor. Reset the overload protection (see page 35)
Planed surface not smooth	<ul style="list-style-type: none"> Infeed too fast Blunt knives Irregular feed 	<ul style="list-style-type: none"> Reduce infeed speed Replace knives Apply constant pressure and reduce feed
Rpm drops during planing	<ul style="list-style-type: none"> Chip removal too important 	<ul style="list-style-type: none"> Reduce chip removal



Guide de dépannage

Troubleshooting guide



NL

PROBLEEM	OORZAAK	OPLOSSING
De machine kan niet worden ingeschakeld	<ul style="list-style-type: none"> • Geen voeding • De stroomonderbreker is geactiveerd 	<ul style="list-style-type: none"> • Controleer de status van het netwerk • Reset de stroomonderbreker
De machine wordt uitgeschakeld automatisch tijdens inactiviteit	<ul style="list-style-type: none"> • Geen voeding 	<ul style="list-style-type: none"> • Controleer de zekeringen • Door de ingebouwde laagspanningsbeveiliging start de machine niet automatisch opnieuw op. Wanneer de spanning terugkeert, moet de machine opnieuw worden gestart (zie pagina 35)
De machine stopt tijdens het schaven	<ul style="list-style-type: none"> • De overbelastingsbeveiliging reageert op botte messen, te snelle invoer of te dikke spaanafvoer 	<ul style="list-style-type: none"> • Alvorens verder te werken, de messen vervangen of de motor laten afkoelen. Overbelastingsbeveiliging resetten (zie pagina 35)
Overbelastingsbeveiliging schakelt uit	<ul style="list-style-type: none"> • Te veel fiches • Te snel voeren • Botte messen 	<ul style="list-style-type: none"> • Alvorens verder te werken, de messen vervangen of de motor laten afkoelen. Overbelastingsbeveiliging resetten (zie pagina 35)
Geschaafd oppervlak niet glad	<ul style="list-style-type: none"> • Te snel voeren • Botte messen • Onregelmatige voeding 	<ul style="list-style-type: none"> • Verlaag de voersnelheid • Vervang de messen • Oefen constante druk uit en verminder de voeding
Snelheid neemt af tijdens het werk	<ul style="list-style-type: none"> • Overmatige spaanafvoer 	<ul style="list-style-type: none"> • Verklein de pashoogte

ES

PROBLEMA	CAUSA	SOLUCIÓN
La máquina no se puede encender	<ul style="list-style-type: none"> • Sin fuente de alimentación • El disyuntor se ha disparado 	<ul style="list-style-type: none"> • Verificar el estado de la red • Restablecer el disyuntor
La máquina se apaga automáticamente durante el funcionamiento inactivo	<ul style="list-style-type: none"> • Sin fuente de alimentación 	<ul style="list-style-type: none"> • Revise los fusibles • Debido a la protección de bajo voltaje incorporada, la máquina no se reinicia automáticamente. Cuando vuelva el voltaje, la máquina debe reiniciarse. (vea la página 35)
La máquina se detiene durante el cepillado	<ul style="list-style-type: none"> • La protección contra sobrecargas reacciona debido a cuchillos desafilados, alimentación demasiado rápida o eliminación de virutas demasiado gruesas 	<ul style="list-style-type: none"> • Antes de continuar con el trabajo, reemplace las cuchillas o deje que el motor se enfríe. Restablecer protección contra sobrecarga (ver página 35)
Disparo de protección contra sobrecarga	<ul style="list-style-type: none"> • Demasiadas fichas • Alimentarse demasiado rápido • Cuchillos desafilados 	<ul style="list-style-type: none"> • Antes de continuar con el trabajo, reemplace las cuchillas o deje que el motor se enfríe. Restablecer protección contra sobrecarga (ver página 35)
Superficie cepillada no lisa	<ul style="list-style-type: none"> • Alimentarse demasiado rápido • Cuchillos desafilados • Alimentación irregular 	<ul style="list-style-type: none"> • Reducir la velocidad de alimentación • Reemplazar las cuchillas • Aplicar presión constante y reducir el avance
Disminuye la velocidad durante el trabajo	<ul style="list-style-type: none"> • Evacuación excesiva de virutas 	<ul style="list-style-type: none"> • Reducir la altura del pase



Guide de dépannage

Troubleshooting guide



IT

PROBLEMA	CAUSA	SOLUZIONE
A máquina não pode ser ligada	<ul style="list-style-type: none"> • Sem fonte de alimentação • O disjuntor desarmou 	<ul style="list-style-type: none"> • Verifique o estado da rede • Reinicie o disjuntor
A máquina desliga automaticamente durante a operação inativa	<ul style="list-style-type: none"> • Sem fonte de alimentação 	<ul style="list-style-type: none"> • Verifique os fusíveis • Devido à proteção embutida de baixa tensão, a máquina não reinicia automaticamente. Quando a tensão retornar, a máquina deve ser reiniciada. (ver página 35)
A máquina para durante o aplainamento	<ul style="list-style-type: none"> • A proteção contra sobrecarga reage devido a facas cegas, alimentação muito rápida ou remoção de cavacos muito espessos. 	<ul style="list-style-type: none"> • Antes de continuar a trabalhar, recolque as lâminas ou deixe o motor esfriar. Reinicializar a proteção de sobrecarga (ver página 35)
Disparo de proteção contra sobrecarga	<ul style="list-style-type: none"> • Muitas fichas • Alimentando-se muito rápido • Facas cegas 	<ul style="list-style-type: none"> • Antes de continuar a trabalhar, recolque as lâminas ou deixe o motor esfriar. Reinicializar a proteção de sobrecarga (ver página 35)
Superfície aplainada não lisa	<ul style="list-style-type: none"> • Alimentando-se muito rápido • Facas cegas • Alimentação irregular 	<ul style="list-style-type: none"> • Reduza a velocidade de alimentação • Substitua as facas • Aplique pressão constante e reduza o avanço
Diminui a velocidade durante o trabalho	<ul style="list-style-type: none"> • Evacuação excessiva de cavacos 	<ul style="list-style-type: none"> • Reduzir a altura da passagem

PT

PROBLEMA	CAUSA	SOLUTION
La macchina non può essere accesa	<ul style="list-style-type: none"> • Nessuna alimentazione • L'interruttore automatico è scattato 	<ul style="list-style-type: none"> • Controllare lo stato della rete • Ripristinare l'interruttore automatico
La macchina si spegne automaticamente durante il funzionamento a vuoto	<ul style="list-style-type: none"> • Nessuna alimentazione 	<ul style="list-style-type: none"> • Controllare i fusibili • A causa della protezione da bassa tensione incorporata, la macchina non si riavvia automaticamente. Al ritorno della tensione è necessario riavviare la macchina. (vedi pagina 35)
La macchina si ferma durante la piallatura	<ul style="list-style-type: none"> • La protezione da sovraccarico reagisce a causa di coltelli smussati, avanzamento troppo veloce o asportazione di truciolo troppo spesso 	<ul style="list-style-type: none"> • Prima di continuare a lavorare, sostituire le lame o lasciare raffreddare il motore. Ripristina protezione da sovraccarico (vedi pagina 35)
Intervento protezione da sovraccarico	<ul style="list-style-type: none"> • Troppe patatine • Alimentazione troppo veloce • Coltelli smussati 	<ul style="list-style-type: none"> • Prima di continuare a lavorare, sostituire le lame o lasciare raffreddare il motore. Ripristina protezione da sovraccarico (vedi pagina 35)
Superficie piallata non liscia	<ul style="list-style-type: none"> • Alimentazione troppo veloce • Coltelli smussati • Alimentazione irregolare 	<ul style="list-style-type: none"> • Ridurre la velocità di alimentazione • Sostituire i coltelli • Applicare una pressione costante e ridurre l'alimentazione
La velocità diminuisce durante il lavoro	<ul style="list-style-type: none"> • Eccessiva evacuazione truciolo 	<ul style="list-style-type: none"> • Ridurre l'altezza di passaggio





EnergyPlane-305ASP 132455 MBY12-1	Raboteuse Dégauchisseuse Elektrische Schaafmachine Piaalla eletrica Maquina de Aplainar Piaalla eletrica Planer thicknesser
---	--

	Puissance assignée: Nominal power: Leertlaufdrehzahl: Potencia fijada: Potência assegnata: Potência assinada:	1800 W
---	--	---------------

	Vitesse à vide: Leertlaufdrehzahl: Velocidad vacía: Velocidade no vácuo: Velocità a vuoto: No-load speed:	6700 min⁻¹
---	--	------------------------------

	Tension et fréquence assignée: Aangewezen spanning en frequentie: Tensión y frecuencia fijada: Tensão e frequência fixa: Tensione e frequenza assegnata: Nominal frequency and power:	230 V ~ 50 Hz
---	--	----------------------

	Niveau de pression acoustique : Niveau akoestische druk : Nível de presión acústica : Nível de pressão acústica : Livello di pressione acustica : Acoustic pressure level :	83,2 dB (A)
---	--	--------------------

	Niveau de puissance acoustique : Niveau akoestisch vermogen : Nível de potencia acústica : Nível de potência acústica: Livello di potenza acustica: Acoustic power level :	96,2 dB (A)
--	---	--------------------

	Dimensions table Afmetingen tafel Dimensiones mesa Dimensioni tabella Dimensões da mesa working table dimensions	1075x305 - 500x305 mm
---	---	--

	Porter des lunettes de sécurité : Porter un masque anti-poussière: Porter une protection auditive: porter des gants : Schutzbrille tragen : Staubschutzmaske tragen : Gehörschutz tragen: Handschuhe tragen: Draag een veiligheidsbril : Draag een stofmasker : Draag gehoorbeschermers: draag handschoenen: Llevar puestas gafas protectoras : Llevar puesta una carèta de protección contra el polvo : Llevar puesta una protección auditiva: usar guantes Portare de gli occhiali di sicurezza : Indossare una mascherina anti-polvere : Portare una protezione uditiva: indossare i guanti: Utilizar óculos de seguridad : Utilizar una máscara anti-poeira : Utilizar uma proteção auditiva: usar luvas: Wear protective eyewear : Wear a dust mask : Wear hearing protective equipment: wear gloves :	X
---	--	----------

NIVEAU SONORE D'EMISSION :

A VIDE

Pression acoustique LpA poste opérateur	83,2 dB
Incertitude	3
Puissance acoustique LWA	96,2 dB
Incertitude	3

Valeurs déterminées suivant le code d'essai de l'annexe B de la norme EN 61029-1

avec emploi des normes de base ISO 11201 et ISO 3744.

Les niveaux de pression acoustique obtenus in situ dépendent:

- Des niveaux réels de la machine considérée, en prenant en compte les incertitudes déclarées.
- Du local et de l'installation de la machine. Préférez une pièce dont l'acoustique est plus feutrée. Evitez les pièces vide à grande résonance. Placez vous auprès d'une fenêtre le cas échéant.
- Des outils montés, des pièces travaillées, des réglages choisis,...

Information :

- La ou les valeurs totales déclarées de vibration et la ou les valeurs déclarées d'émission sonore ont été mesurées conformément à une méthode d'essai normalisée et peuvent être utilisées pour comparer des outils ;
- La ou les valeurs totales déclarées de vibration et la ou les valeurs déclarées d'émission sonore peuvent aussi être utilisées dans une évaluation préliminaire de l'exposition.

Mise en garde :

- L'émission de vibration et l'émission sonore pendant l'utilisation de l'outil électrique peuvent être différentes des valeurs déclarées selon les façons d'utiliser l'outil, en particulier le type de pièce à usiner; et
- Il est nécessaire d'identifier les mesures de sécurité destinées à protéger l'opérateur qui sont basées sur une estimation de l'exposition dans les conditions réelles d'utilisation (en prenant en compte toutes les parties du cycle de manœuvres, telles que les moments où l'outil est hors tension et où il fonctionne à vide, en plus du temps d'actionnement de la manette).



<p>Soumis à recyclage : Niet wegwerpen :  Sottoposti a riciclaggio : Sujeitos à reciclagem : Sottoposti a riciclaggio : Subjected to recycling :</p>	X
---	----------

<p> Poids : Gewicht: Peso: Peso: Peso: Weight:</p>	93 kg
---	--------------

FR-Recyclage des déchets:

Les outils, accessoires et leur emballages doivent suivre une voie de recyclage adaptée. Conformément aux directives Européennes 2012/19/UE et 2006/66/CE, les composants d'un produit doivent être séparés, collectés, recyclés ou éliminés en conformité avec les réglementations environnementales en vigueur. Les appareils, batteries, piles, huiles, emballages devront être déposés dans les systèmes d'élimination des déchets spéciaux tels que déchetteries. Renseignez vous auprès de votre commune pour connaître l'organisme le plus proche à même de retraiter ou de collecter ces déchets.

NL-afval recycling:

gereedschap, accessoires en verpakkingen moeten volgen een pad geschikt is voor recycling. Volgens de Europese richtlijnen 2012/19/UE en 2006/66/CE, de componenten van een product moet worden gescheiden, verzameld, gerecycleerd of verwijderd in overeenstemming met de milieuvorschriften. Apparaten, batterijen, olie, moet de verpakking worden gedeponneerd in de afvalverwerking afval, zoals stortplaatsen. Neem contact op met uw gemeente naar de dichtstbijzijnde agentschap kunnen herhalen of het verzamelen van deze afvalstoffen te vinden.

ES-Reciclado de los residuos:

Las herramientas, los accesorios y los envases tienen que seguir la vía de reciclaje adecuada. En virtud de las directivas europeas 2012/19/UE y 2006/66/CE, los componentes de un producto deben separarse, recogerse, reciclarse o eliminarse de acuerdo con las reglamentaciones medioambientales vigentes. Los aparatos, baterías, pilas, aceites, envases deberán llevarse a los centros de eliminación de residuos especiales tales como los ecoparques. Pedir información al municipio para conocer el centro más cercano apto para reciclar o recoger dichos residuos.

PT-Reciclagem do lixo:

As ferramentas, acessórios e suas embalagens devem seguir um canal de reciclagem adaptado. Conforme as diretivas europeias 2012/19/UE e 2006/66/CE, os componentes de um produto devem ser separados, recolhidos, reciclados ou eliminados de acordo com as regulamentações ambientais em vigor. Os aparelhos, baterias, pilhas, óleos e embalagens deverão ser depositados nos sistemas de eliminação de detritos especiais, tais como unidades de triagem de detritos. Informar-se junto ao seu concelho municipal para conhecer o órgão mais próximo habilitado a evacuar ou recolher estes detritos.

IT-Riciclaggio dei rifiuti:

Gli apparecchi, i loro accessori ed imballaggi devono essere sottoposti ad un processo di riciclaggio appropriato. In conformità con le direttive europee 2012/19/UE e 2006/66/CE, i componenti di un prodotto devono essere separati, raccolti, riciclati o smaltiti in conformità con le normative ambientali in vigore. Gli apparecchi, le batterie, le pile, gli oli, gli imballaggi dovranno essere conferiti nei sistemi di smaltimento dei rifiuti speciali come le isole ecologiche. Informarsi presso il proprio comune per sapere qual è l'ente più vicino in grado di fare il trattamento o la raccolta differenziata di questi rifiuti

EN-Waste recycling:

The tools, accessories and their packaging must use an appropriate recycling channel. In compliance with European Directives 2012/19/UE and 2006/66/CE, a product's components must be separated, collected, recycled or eliminated in accordance with the environmental regulations in force. The appliance, batteries, oils and packaging must be deposited in the special waste elimination systems such as the waste collection centres. Ask your commune for information on the nearest organisation in a position to reprocess or collect this waste

<p> Danger : Gevaar: Peligro: Perigo: Pericolo: Danger:</p>	X
--	----------

<p> 305 mm</p>	305 mm
---	---------------

<p> Recyclable, soumis au tri sélectif: Recyclable, subject to recycling: Recyclebaar, onder voorbehoud van het sorteren: Reciclable, sin perjuicio de la clasificación: Reciclável, sujeito a triagem: Riciclabile, soggetto a cernita:</p>	X
---	----------

<p>Classe d'isolement : 1 Isolatie Klasse : 1 Aislamiento clase :1 Isolamento classe :1 isolamento classe :1 Insulation class : 1</p>	X
--	----------

<p> X</p>	X
--	----------

<p> Risque de sectionnement des doigts ou de la main : Snijden risico van de vinger of hand: Recyclebaar, onder voorbehoud van het sorteren: Seccionamiento riesgo del dedo o de la mano: Risco Seccionamento do dedo ou a mão: Sezionamento rischio del dito o della mano:</p>	X
--	----------

<p> Lire les instructions avant usage : Lees voor het gebruik de instructies : Léase las instrucciones antes de usar : Ler as instruções antes da utilização : Leggere le istruzioni prima dell'uso : Read the instructions before use :</p>	X
---	----------

<p> Conformité européenne : Voldoet aan de EG-normen: Cumple con las directivas CE: Conforme às normas CE: Conforme alle norme CE: Conforms to EC standards:</p>	X
---	----------

<p> 3 mm</p>	3 mm
---	-------------



132455 EnergyPlane-305ASP

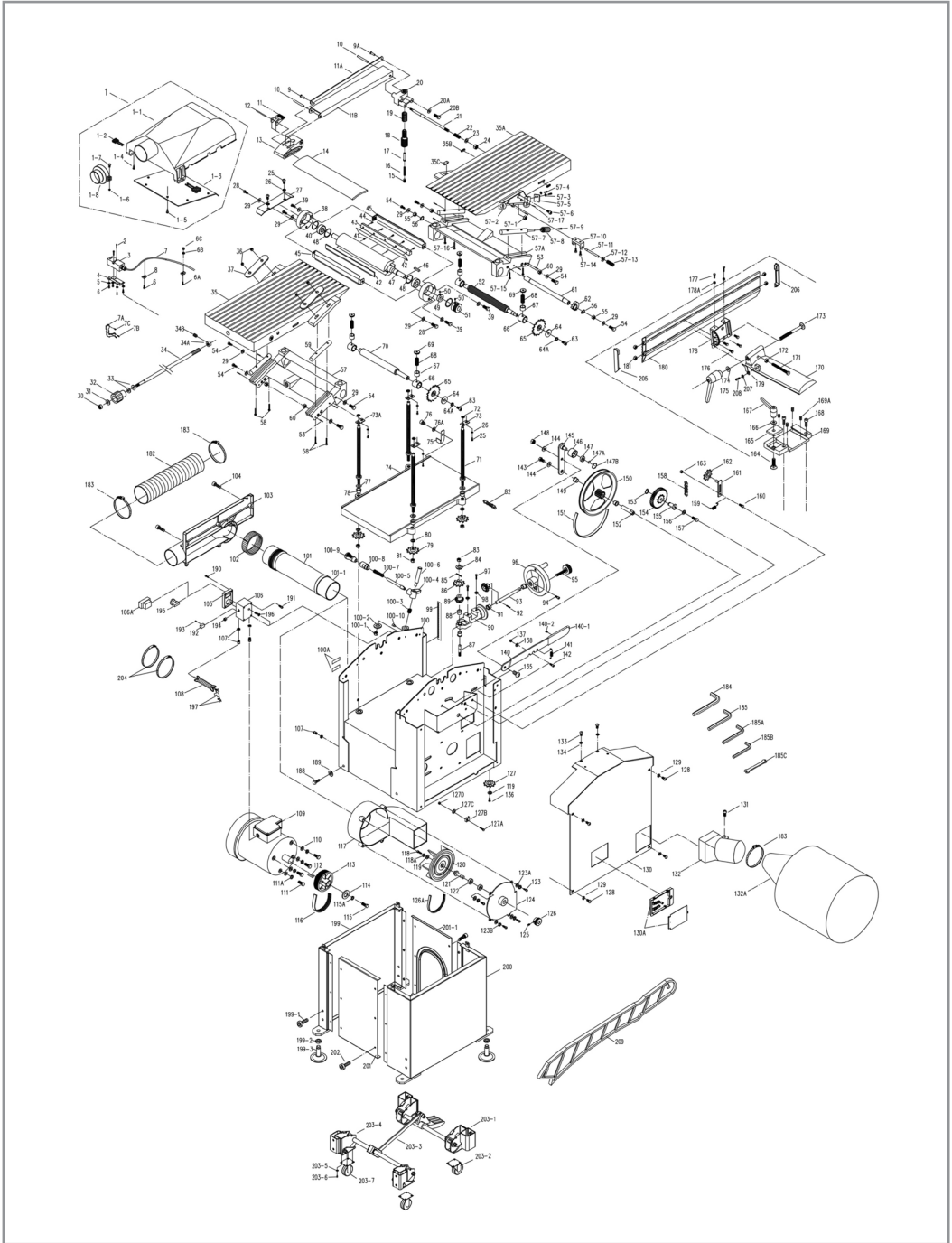



DECLARATION CE DE CONFORMITE
DECLARACION DE CONFORMIDAD
DICHIARAZIONE DI CONFORMITA

VERKLARING VAN OVEREENSTEMMING
DECLARAÇÃO DE CONFORMIDADE
DECLARATION OF CE CONFORMITY

Le soussigné,
Ondergetekende,
El suscrito,
O abaixo assinado,
Il sottoscritto,
The undersigned,

PEUGEOT OUTILLAGE

192, Avenue Yves Farge - 37700 St. Pierre-des-Corps - FRANCE

Tél. : 02 36 16 71 46 - Fax : 02 36 16 71 40

Déclare par la présente que,
Verklaart hiermede dat,
Declaro por la presente que,
Declaro pela presente que,
Dichiari che,
Declares that,

CODE

PEUGEOT / EnergyPlane-305ASP / 132455 / MBY12-1

Raboteuse Dégauchisseuse / Elektrische Schaafmachine / Pialla elettrica
Maquina de Aplanar / Pialla elettrica / Planer thicknesser

Est conforme et satisfait aux normes CE:
In overeenstemming is met en Voldoet aan EG richtlijnen:
Cumple con la directivas de la CE:
Respeita e está em conformidade com as normas CE:
È conforme alle direttive CEE:
Complies with the EEC standards:

MD 2006/42/EC, EMC 2014/30/EU, 2011/65/EU
2015/863/EU

EN61029-1 :2009+A11 :2010
EN61029-2-3:2011
EN IEC 55014-1:2021
EN IEC55014-2:2021
EN IEC 61000-3-2:2019/A1:2021
EN 61000-3-3:2013/A2:2021

Personne autorisée à
constituer le dossier technique :
Christophe HUREL



SIGMA

Présidente de PEUGEOT OUTILLAGE
Représentée par son Président :
Christophe HUREL
15/09/2022
Fait à St. Pierre-des-Corps

Attestation de type (EC type) N° M6A 028954 0084 Rev. 00

Rapport (report) N° 4840319536300

TUV SÜD Product service GmbH
Ridlerstrasse 65 - 80339 München - GERMANY
Enregistré sous (registred under) N° 0123

DATE _____ SERIE _____ MBY12-1

PEUGEOT

132455 EnergyPlane-305ASP

1800 W 230V-50 Hz 6700 min-1 305 mm 160 mm 1075x305 mm 0-3 mm

Aspiration 93 kg ø 75 mm

Peugeot Outillage - 192, Avenue Yves Farge - 37700 Saint-Pierre-des-Corps - FRANCE

132455-Sticker-B-01-Normes.indd 1 03/03/2023 08:51

**Attention !
Warning !**

- Pour votre propre sécurité, lisez avec attention et compréhension le manuel d'instruction.**
For your own safety read and fully understand the instruction manual before operating the planer or thicknesser.
- Portez toujours des lunettes de sécurité.**
Always wear approved safety glasses.
- Gardez toujours les lames et les fers en place et en bon état de fonctionnement.**
Always keep cutter-block and knife guards in place and in proper working condition. Do not remove the guard for rebating, or similar operations.
- Ne jamais faire de rabotage ou dégauchir plus de 2 mm par passe.**
Never make planing or thicknessing cuts of more than 2 mm per pass.
- Ne jamais faire de rabotage ou dégauchir du bois plus court que 206 mm de longueur.**
Never make planing or thicknessing cuts on timber shorter than 206 mm in length.
- Ne pas exposer la machine à la pluie ou à l'humidité.**
Do not expose the machine to rain, or use in damp locations.
- N'utilisez la machine qu'avec un seul type de bois.**
To avoid kickbacks, use the machine for single surfacing only.

**Attention !
Warning !**

PEUGEOT

For Planing

For Thicknessing

- Couper l'alimentation avant d'assembler le récupérateur de poussière.
Disconnect power supply before the dust chute being assembled completely.
- Pour dégauchissage : placer le récupérateur de poussière sous la table de travail.
For thicknessing : locate the dust chute under the working table.
- Pour la fonction rabot : placer le récupérateur de poussière sur la table de travail (avec la table à déplaç en position haute).
For planing : locate the dust chute on top of the working table (with thicknessing table in the shortest position).
- Alignez le récupérateur de poussière avec les trous rectangulaires situés de chaque côté de la table de travail. Insérez les deux clés de fixation côté dans les trous rectangulaires.
The dust chute should be so located that the rectangular holes both on dust chute and on the side of working table to be in line with each other and then insert the 2 keys into the rectangular holes on both sides.
- Les clés doivent être complètement insérées pour activer le micro-commutateur. Les clés doivent être complètement insérées pour activer le micro-commutateur. The keys should be inserted completely to switch on the micro-switch.

132455-Sticker-B-02-Warning.indd 1 14/02/2023 12:20

ASP System By PEUGEOT

Aspiration intégrée
Dust cyclone inside

Jusqu'à / Up to **91%** de copeaux récupérés
of dust recovered

Système d'aspiration des copeaux avec sac de récupération des poussières intégré (110 Litres)
Wood chips extraction system with integrated dust extraction bag (110 Liters)

132455-2-Sticker-C-04-poussieres.indd 1 12/02/2024 09:07





5 ANS 10 ANS
GARANTIE / RÉPARABILITÉ

BON DE GARANTIE

1 - Objet de la garantie :
La garantie porte exclusivement sur les vices de fabrication ou les vices de matières.
Elle nous oblige à l'échange ou à la réparation des pièces reconnues hors d'usage.

2 - Durée de la garantie :
La garantie est de 60 mois à dater de la livraison du matériel à l'utilisateur (facture ou ticket de caisse à fournir). Les échanges ou réparations faites au titre de la garantie ne peuvent avoir pour effet de prolonger celle-ci.

3 - Réserves :
La garantie ne s'applique en aucun cas aux réparations effectuées en dehors de nos réparateurs agréés.
En aucun cas, durant la période de garantie, le matériel ne devra être démonté.

GARANTIEKAART

1 - Doel van de garantie:
De garantie heeft uitsluitend betrekking op fabricagefouten of gebreken in materialen.
Het dwingt ons om uit te wisselen of reparatie van erkende onbruikbare onderdelen.

2 - Duur van de garantie:
De garantie bedraagt 60 maanden vanaf de levering van apparatuur voor de gebruiker (factuur of kassabonnet verstrekken).
De uitwisseling of reparaties onder garantie niet te verlengen.
GO verzendkosten zijn voor rekening van de gebruiker.

3 - Reserves:
De garantie geldt niet in alle reparaties die buiten onze goedgekeurde reparateurs.
In ieder geval gedurende de garantie, moet het materiaal worden verwijderd.

TARJETA DE GARANTÍA

1 - Objeto de la garantía:
La garantía sólo se referirá a los defectos de fabricación o defectos en los materiales.
Nos obliga a cambiar o reparación de las piezas fuera de servicio reconocido.

2 - Duración de la garantía:
La garantía es de 60 meses a partir de la entrega de equipos para el usuario (factura o recibo que se den). Los intercambios o reparaciones bajo garantía no tendrá que prolongarse.
GO gastos de envío correrán a cargo del usuario.

3 - Reservas:
La garantía no se aplica en todas las reparaciones realizadas fuera de nuestros talleres de reparación autorizados.
En cualquier caso, durante el período de garantía, el material debe ser removido.

CARTÃO DE GARANTIA

1 - Finalidade da garantia:
A garantia só relacionar com defeitos de fabricação ou defeitos em materiais.
Ela nos obriga a troca ou reparo de peças inservíveis reconhecidos.

2 - Duração da Garantia:
A garantia é de 60 meses a partir da entrega de equipamentos para o usuário (factura ou recibo a ser fornecido). Trocas ou reparos sob a garantia não terá que prolongá-la.
GO porte serão custeadas pelo usuário.

3 - Reservas:
A garantia não se aplica a quaisquer reparos feitos fora das nossas oficinas aprovadas.
Em qualquer caso, durante o período de garantia, o material deve ser removido.

GARANZIA

1 - Oggetto della garanzia:
La garanzia si riferisce esclusivamente alla difetti di fabbricazione o difetti nei materiali.
Ci costringe a scambio o la riparazione di parti inutilizzabili riconosciuti.

2 - Durata della garanzia:
La garanzia è di 60 mesi dalla consegna delle attrezzature per l'utente (fattura o ricevuta da fornire).
Scambi o riparazioni in garanzia non sarà necessario prolungarla.
GO spese di spedizione sono a carico dell'utente.

3 - Reserve:
La garanzia non si applica in tutte le riparazioni effettuate al di fuori dei nostri riparatori autorizzati.
In ogni caso, durante il periodo di garanzia, il materiale deve essere rimosso.

WARRANTY

1 - Scope of the warranty :
The warranty shall only apply to manufacturing defects or material defects.
We are obliged to exchange or repair parts that are identified as being unusable

2 - Lifetime warranty :
The warranty shall be valid for 60 months from the delivery date of the equipment to the user (invoice or bill receipt must be provided).
Exchanges or repairs carried out under the warranty shall not extend the original warranty period.
The user shall be responsible for original shipping charges.

3 - Reservations :
The warranty shall not under any circumstances cover repairs carried out by a non-authorized repairer.
The equipment should not be dismantled under any circumstances during the warranty period.

Date d'achat	Référence machine	Cachet du distributeur
Datum van aankoop	Machine referentie	Dealer stempel
Fecha de compra	Referencia de la máquina	Comerciante de sellos
Data da compra	Referência de máquina	Selo Revendedor
Data di acquisto	Riferimento macchina	Timbro del rivenditore
Purchase date	Machine code	Distributor's stamp

SERVICE APRÈS VENTE - AFTER SALE SERVICE

PEUGEOT OUTILLAGE - 192, Avenue Yves Farge - 37700 St. Pierre-des-Corps - FRANCE - Tél. : 02 36 16 71 46 - Fax : 02 36 16 71 40



PEUGEOT OUTILLAGE

Une société du groupe **SIGMA**

192, Avenue Yves Farge
37700 St. Pierre-des-Corps
FRANCE
contact@peugeot-outillage.com
peugeot-outillage.com

