

PEUGEOT



EnergyDrill-1 8VP40N



PEUGEOT OUTILLAGE

250317-MANUAL-C-20210517

FR MANUEL D' UTILISATION (Notice originale):
NL HANDBOEK (Vertaling van het oorspronkelijke):
ES MANUAL (Traducción del original):
PT MANUAL (Tradução do manual original):
IT MANUAL (Traduzione dell'avvertenza originale):
EN USING MANUAL (Original manual translation):

*Perceuse à percussion sans fil
Draadloze percussie boor
Taladro de percusión sin cuerda
Broca de percussão sem fio
Trapano a percussione cordless
Cordless percussion Drill*

peugeot-1810.com

Cet outil sert à visser et dévisser librement, sans être relié à une prise de courant, mais sert également à percer dans le bois, le plastique et le métal, avec des forets adaptés.

- Pour visser ou dévisser, il faut insérer un embout de vissage adapté à la forme de la vis dans le mandrin.

Exemple d'embout de vissage :



- Les vitesses mécaniques, si votre machine en est équipée, ont le rôle d'une boîte de vitesse:
Vitesse lente = couple maxi (force) - utilisation en fonction vissage
Vitesse élevée = couple réduit - utilisation en fonction perçage

- Plus on appuie sur l'interrupteur variateur et plus la vitesse de rotation du mandrin augmente.

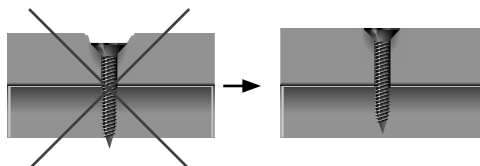

- Le réglage de couple, si votre machine en est équipée, permet après sélection de celui ci, de faire débrayer le moteur (arrêt de la fonction vissage) pour une force de serrage correspondante. Ceci permet de visser toujours à une même profondeur et évite de détériorer le support. Très utile pour le vissage de plaques de placoplâtre ou l'assemblage de stratifié par exemple.



- Adapter la vitesse de rotation du mandrin au diamètre du foret:
- Petit diamètre = grande vitesse
- Gros diamètre = petite vitesse

T La fonction percussion, si votre machine en est équipée, permet de percer dans les matériaux (pierre, béton, brique ..). La machine doit être munie d'un foret à béton avec extrémité en carbure.

- Il existe différents types de forets:

- Foret à bois (pour percer dans le bois) ————— 
- Foret à métaux (pour percer dans le métal et le plastique) ————— 
- Foret à béton (pour percer dans la maçonnerie) ————— 

- Il existe différents types de chargeur:
- rapide = maxi 1 heure
- lent = entre 3 et 5 heures

Pour une optimisation du temps de travail, 2 batteries sont recommandées.

- Certaines visseuses sont équipées de batteries rotatives (exemple : 180 °), afin d'optimiser l'équilibrage et d'accéder plus facilement à la zone de travail.
- Le niveau, si votre machine en est équipée, permet de travailler perpendiculairement sur une surface verticale.
- L'affichage digital, si votre machine en est équipée, permet de lire les réglages pré sélectionnés manuellement (par exemple, la vitesse de rotation)
- La fonction éclairage, si votre machine en est équipée, permet un confort visuel en milieu obscur.
- Le laser, si votre machine en est équipée, permet de projeter un faisceau matérialisant le passage de l'outil.
- La fonction test de la charge de la batterie vous permet de savoir le niveau d'énergie restant dans la batterie.

This tool enables you to screw and unscrew without needing to be anywhere near a mains source, and to drill into wood, plastic and metal, using the suitable drill bits.

- To screw or unscrew, you simply insert a screwdriver bit that fits the shape of the screw into the chuck.

Screwdriver bit example :



- The mechanical speeds, if your machine has them, function like a gear box:
 Slow speed (to be used for the screwdriver function) = maximum torque (force).
 High speed (to be used for drilling) = reduced torque.
- The harder you press the trigger button, the faster the chuck rotates.

- The torque adjustment, if your machine is fitted with this, means that you can set the required torque, by disengaging the motor (stopping the screwdriver function).
 This means that you can screw to a uniform depth, without damaging the material you are screwing into. Very useful for screwing into plasterboard or laminates, for example.

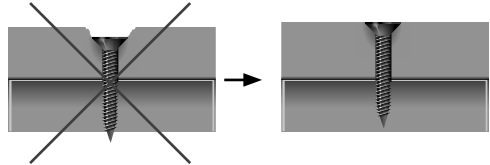

- Adapt the rotation speed of the chuck to the diameter of the drill:
 - Small diameter = high speed
 - Large diameter = low speed.

T The impact function, if your machine has it, means that you can drill into building materials, for example: stone, concrete, brick...
 The machine must be fitted with a masonry drill. (carbide tip)

- There are a number of different drill types:
 - Wood drill (for drilling into wood)
 - Metal drill (for drilling into metal and plastic)
 - Masonry drill (for drilling into concrete and brick)

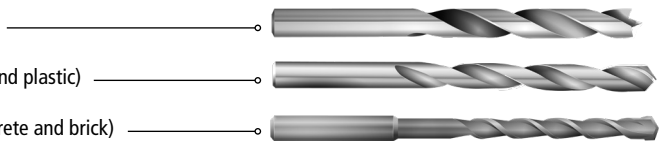

- There are various types of battery charger:
 - rapid = max. 1 hour
 - slow = between 3 and 5 hours

To optimise your working time, it is recommended that you use 2 batteries.

- Certain electric screwdrivers have rotary batteries (for example: 180°), in order to improve the balance of the tool and make it easier to reach certain positions.
- The level gauge, if your machine is fitted with one, makes it possible to ensure that you are working perpendicular to a vertical surface.
- The digital display, if your machine has one, shows the preselected settings (for example, rotation speed)
- The lighting function, if your machine has one, makes it more comfortable to work with in dark environments.
- The laser, if your machine has one, produces a beam of light which shows you where the tool will go.
- The battery charge test function tells you how much energy is left in the battery.

Esta herramienta sirve para atornillar y destornillar libremente, sin estar conectado a ninguna toma de corriente, pero también, con brocas adaptadas, sirve para taladrar en la madera, el plástico y el metal.

- Para atornillar o destornillar hay que insertar en el mandril una boquilla de atornillado adaptada a la forma del tornillo.

Ejemplo destornillador de punta:



- Las velocidades mecánicas, si su máquina está equipada con esta función, desempeñan la función de una caja de cambios: Velocidad lenta (utilizar según el atornillado) = par máximo (fuerza)
Velocidad elevada (utilizar según el taladrado) = par reducido

- Cuanto más se pulsa el interruptor variador, más aumenta la velocidad de rotación del mandril.

• El ajuste de par, si su máquina está equipada con esta función, permite, después de haberlo seleccionado, desembragar el motor (parada de la función atornillado) para obtener una fuerza de atornillado adecuada. Esto permite atornillar siempre hasta una misma profundidad evitando así el deterioro del soporte. Muy útil por ejemplo para el atornillado de placas de yeso o el ensamblaje de laminado.

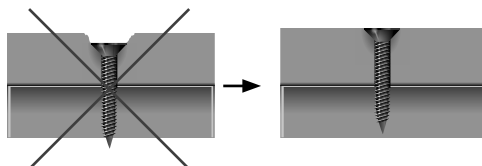

- Adaptar la velocidad de rotación del mandril al diámetro de la broca:

- Diámetro pequeño = velocidad elevada
- Gran diámetro = pequeña velocidad.

T

La función percusión, si su máquina está equipada con esta función, permite por ejemplo taladrar los siguientes materiales: piedra, hormigón, ladrillo ... La máquina tiene que estar equipada con una broca para el hormigón. (punta de carburo)

- Existen diferentes tipos de brocas:

- Brocas para la madera (para taladrar en la madera) —————
- Brocas para el metal (para taladrar en el metal y el plástico) —————
- Brocas para hormigón (para taladrar en la mampostería) —————

- Existen diferentes tipos de cargadores:

- rápido = como máximo 1 hora
- lento = entre 3 y 5 horas

Para una optimización del tiempo de trabajo, se recomienda el uso de 2 baterías.

• Determinados atornilladores están equipados con baterías rotativas (por ejemplo: 180 °), con el fin de optimar el equilibrado y de acceder más fácilmente a la zona de trabajo.

- El nivel, si su máquina está equipada con esta función, permite trabajar perpendicularmente en una superficie vertical.
- La visualización digital, si su máquina está equipada con esta función, permite leer los ajustes preseleccionados manualmente (por ejemplo, la velocidad de rotación)
- La función iluminación, si su máquina está equipada con esta función, ofrece un confort visual en los lugares oscuros.
- El láser, si su máquina está equipada con esta función, permite proyectar un haz que materializa el paso de la herramienta.
- La función prueba de la carga de la batería le permite conocer el nivel de energía de la batería.

Questo utensile serve ad avvitare e svitare liberamente, senza essere legati ad una presa di corrente, ma serve anche a forare il legno, la plastica e il metallo, con delle punte specifiche.

- Per avvitare o svitare, occorre inserire una punta a cacciavite adattata alla forma della vite nel mandrino.

Esempio punta di cacciavite:



- Le velocità meccaniche, se la vostra macchina ne ha, hanno il ruolo di cambio:
Velocità lenta (utilizzare in funzione avvitamento) = coppia massima (forza)
Velocità elevata (utilizzare in funzione foratura) = coppia ridotta.

- Più si preme sull'interruttore variatore e più la velocità di rotazione del mandrino aumenta.

- La regolazione della coppia, se la vostra macchina ne ha una, permette, dopo averla selezionata, di disinnestare il motore (arresto della funzione avvitamento) per una forza di serraggio corrispondente. Ciò permette di avvitare sempre alla stessa profondità ed evita di danneggiare il supporto. Molto utile per avvitare le lastre di cartongesso o per esempio assemblare gli stratificati.

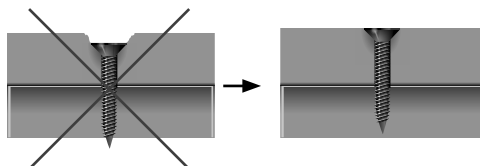

- Adattare la velocità di rotazione del mandrino al diametro della punta:

- Piccolo diametro = grande velocità
- Grande diametro = piccola velocità.

T La funzione percussione, se la vostra macchina ne è munita, permette di forare i materiali, per esempio: pietra, cemento, mattoni La macchina deve essere munita di una punta per cemento. (estremità in carburo)

- Esistono diversi tipi di punte:

- Punta per legno (per forare il legno)

- Punta per metalli (per forare il metallo e la plastica)

- Punta per cemento (per forare nella muratura)



- Esistono diversi tipi di caricatore:

- rapido = massimo 1 ora
- lento = tra 3 e 5 ore

Per un'ottimizzazione del tempo di lavoro, si consigliano 2 batterie.

- Alcune avvitatrici sono munite di batterie rotative (esempio: 180 °), per ottimizzare l'equilibratura e accedere più facilmente alla zona di lavoro.

- La livella, se la vostra macchina ne ha una, permette di lavorare perpendicolarmente su una superficie verticale.

- La visualizzazione digitale, se la vostra macchina ne ha una, permette di leggere le regolazioni preselezionate manualmente (per esempio, la velocità di rotazione)

- La funzione illuminazione, se la vostra macchina ne ha una, permette un comfort visivo nell'oscurità.

- Il laser, se la vostra macchina ne ha uno, permette di proiettare un fascio che materializza il passaggio dell'utensile.

- La funzione test di carico della batteria permette di conoscere il livello d'energia che rimane nella batteria.

Esta ferramenta permite tanto aparafusar e desaparafusar livremente, sem ligação a uma tomada eléctrica, como também abrir orifícios em madeira, plástico e metal, com brocas adaptadas.

- Para aparafusar ou desaparafusar, inserir uma ponta de aperto adaptada à forma do parafuso no mandril.

Exemplo bit chave de fenda:



- As velocidades mecânicas, se a sua máquina possuir esta função, actuam como uma caixa de velocidades:
Baixa velocidade (utilizar para o aparafusamento) = binário máximo (força)
Alta velocidade (utilizar para a perfuração) = binário reduzido.

- Quanto mais se pressiona o interruptor variador, maior é a velocidade de rotação do mandril.

- O ajuste do binário, se a sua máquina oferecer esta função, permite, após a sua selecção, desembraiar o motor (interrupção da função de aparafusamento) para uma força de aperto correspondente. Isso permite aparafusar sempre com a mesma profundidade e evita a deterioração do suporte. É um recurso muito útil para o aparafusamento de placas de placogesso ou a montagem de estratificados, por exemplo.

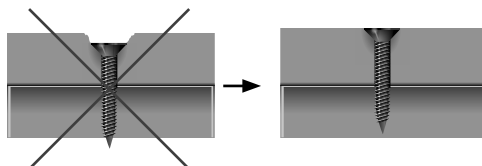

- Adaptar a velocidade de rotação do mandril ao diâmetro da broca:

- Pequeno diâmetro = alta velocidade
- Grande diâmetro = baixa velocidade.

T A função de percussão, se a sua máquina oferecer este recurso, permite abrir orifícios em materiais. Ex.: pedra, betão, tijolo, etc. A máquina deve ser equipada com uma broca para betão (ponta de aço carbono)

- Existem diferentes tipos de brocas disponíveis:

- Broca para madeira (para abrir furos em madeira)



- Broca para metais (para perfurar metal e plástico)



- Broca para betão (para abrir furos em alvenaria)



- Existem diferentes tipos de carregador disponíveis:

- rápido = máx. de 1 hora

- lento = entre 3 e 5 horas

Para a optimização do tempo de trabalho, é recomendável possuir 2 baterias.

- Algumas aparafusadoras vêm equipadas com baterias rotativas (ex.: 180°), a fim de otimizar a equilibragem e facilitar o acesso à zona de trabalho.

- O nível, se a sua máquina oferecer este recurso, permite operar perpendicularmente numa superfície vertical.

- O visor digital, se a sua máquina possuir, permite ler os ajustes pré-seleccionados manualmente (por exemplo, a velocidade de rotação).

- A função de iluminação, se a sua máquina oferecer, permite um maior conforto visual em ambientes escuros.

- El láser, si su máquina está equipada con esta función, permite proyectar un haz que materializa el paso de la herramienta.

- La función prueba de la carga de la batería le permite conocer el nivel de energía de la batería.

Deze tool wordt gebruikt om vast en draai vrij, zonder te zijn aangesloten op een stroombron stroom, maar ook dient om het boren in hout, kunststof en metaal, met geschikte bossen.

- Om schroef-of los te draaien, plaats een hulpmiddel beetje aangepast aan de vorm van de doorn in de schroef.

Voorbeeld schroevendraaier bit:



- Mechanische versnellingen, als uw machine is uitgerust, hebben de rol van een versnellingsbak:
Langzame snelheid = maximumkoppel (kracht) - gebruik schroef functie
= Hoge snelheid laag koppel - gebruik boorfunctie
- Meer indrukken van de schakelaar drive en de rotatiesnelheid van de doorn toeneemt.

- Het koppel instelling als uw machine is uitgerust, maakt selectie mogelijk na deze, om de motor (Zaak schroeven functie) los om een kracht overeenkomstige aanscherping.
Dit kan altijd schroef dezelfde diepte en voorkomt schade aan de vervoerder. Zeer nuttig voor schroeven gipsplaat of assemblage van laminaat, bijvoorbeeld.

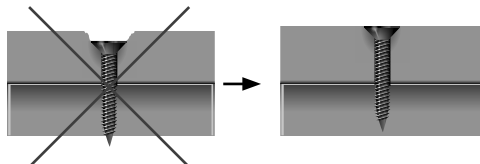

- Pas de snelheid van de rotatie van de doorn boordiameter:
- Kleine diameter hoge snelheid =
- Grote diameter = lage snelheid

T Percussie functie, indien het apparaat is uitgerust, maakt het boren in materialen (steen, beton, baksteen, ...).
De machine moet uitgerust zijn met een steenboor met carbide tip.

- Er zijn verschillende soorten oefeningen:

- Houtboren (voor het boren in hout)

- Metaal boor (voor het boren in metaal en kunststof)

- Betonboren (voor het boren in metselwerk)



- Er zijn verschillende soorten van de lader:

- Rapid = max 1 uur

- Slow = tussen 3 en 5 uur

Voor optimalisatie van de arbeidstijd, worden 2 batterijen aanbevolen.

- Sommige schroevendraaiers zijn voorzien van roterende batterijen (bijvoorbeeld 180 °) om de balans en gemakkelijker toegang tot de werkplek te optimaliseren.
- Het niveau, indien het apparaat is uitgerust, kan verticaal werken op een verticaal oppervlak.
- De digitale display, als uw machine is uitgerust, kan handmatig worden pre selectionnés instellingen lezen (bijvoorbeeld snelheid)
- De verlichting functie, indien het apparaat is uitgerust, maakt visueel comfort in een donkere omgeving.
- De laser, als uw machine is uitgerust, staat het projecteren van een bundel materialiseren de passage van de tool.
- De test batterij kunt u het niveau van de macht van de batterij te leren kennen.



FIG. A



FIG. C

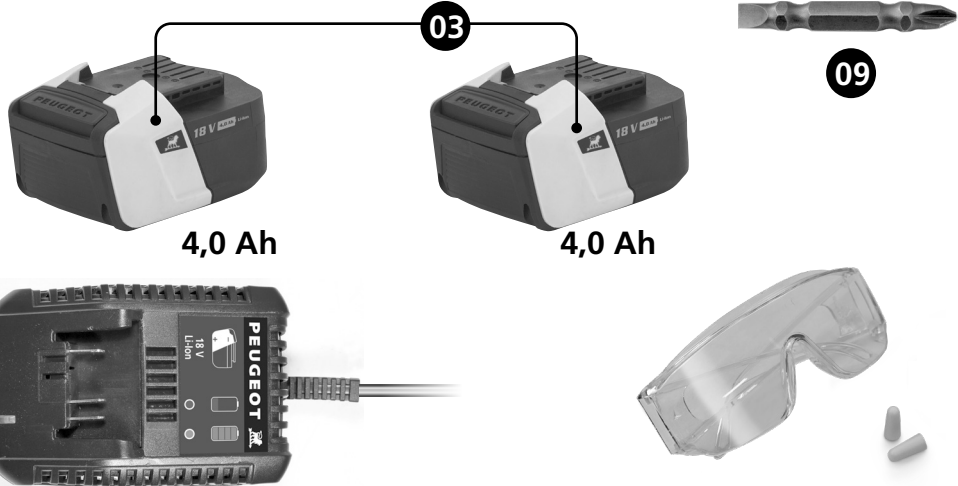
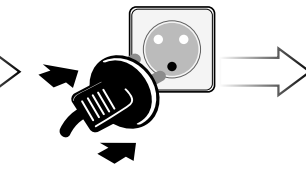



FIG. D

01



Vert/Green/Grün/Verde/Verde/Verde



Brancher le chargeur sur le secteur
Sluit de acculader
Conectar el cargador de batería
Conecte o carregador de bateria
Collegare il caricabatterie
Connect the battery charger

Le témoin de mise sous tension s'allume
De spanningsindicator licht
El indicador de alimentación
As luzes indicadoras de energia
L'indicatore di potenza
The power indicator lights

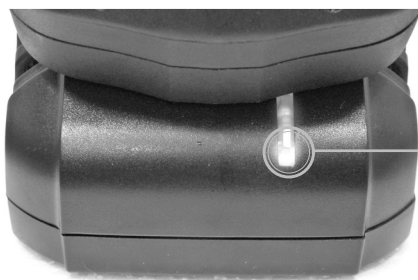

Le témoin de mise en charge s'allume
As luzes indicadoras de carregamento
Las luces indicadoras de carga
As luzes indicadoras de carregamento
L'indicatore di carica
The charging indicator lights

Rouge/Red/Rot/Rojo/Vermelho/Rosso

Chargeur rapide / Quick charger

Disposez rapidement d'une batterie chargée pour commencer le travail rapidement.
Start quickly your work with a quick charging battery.



**FIG. D****01****90 min**

Temps de charge : 90 min. Au bout d'une heure et demie, la LED s'allume en vert; votre batterie est chargée et prête à l'emploi.

Oplaadtijd: 90 min. Na een uur en een half van de LED-verlichting groen; de batterij is opgeladen en klaar voor gebruik.
 Tiempo de carga: 90 min. Después de una hora y media las luces LED verde; la batería está cargada y lista para usar.
 Tempo de carregamento: 90 min. Depois de uma hora e meia as luzes LED verde; a bateria está carregada e pronta para uso.
 Tempo di ricarica: 90 min. Dopo un'ora e mezza il LED verde; la batteria è carica e pronta per l'uso.
 Charging time: 90 min. After an hour and a half, the LED lights green; Your battery is charged and ready for use.

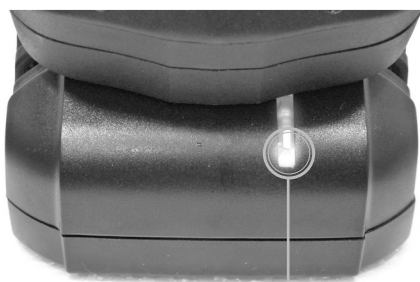

Vert/Green/Grün/Verde/Verde/Verde

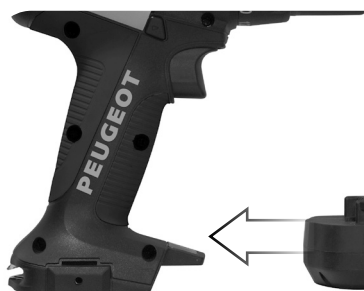

**Votre machine est prête à travailler.
 Uw machine is klaar om te werken.
 Su máquina está lista para trabajar.
 A sua máquina está pronta para trabalhar.
 La macchina è pronta per lavorare.
 Your machine is ready to work**



FIG. D

02



FIG. E

01



① 0-400.min⁻¹

② 0-1500.min⁻¹

Variateur électronique
Elektronische regelaar
Electrónica del inversor
Eletrônica inversor
Variador electrónico
Electronic variable speed

02



Vitesse mécanique 1 (lente) : Gros forets et vissage
mechanische snelheid 1 (langzaam) Grote boren en schroeven
velocidade mecânica 1 (lento) Grandes taladros y tornillos
velocidade mecânica 1 (lento) Grandes brocas e parafuso
velocità meccanica 1 (lento) Grandi punte e vite
mechanical speed 1 (slow) Large drills and screwing



Vitesse mécanique 2 (rapide) : petits forets et vissage
mechanische snelheid 2 (snel) kleine stukjes en schroevendraaiervelocidad
mecânica 2 (rápido): pequenos trozos y destornillador
velocidade mecânica 2 (rápido): pequenos pedaços e chave de fenda
velocità meccanica 2 (veloce): piccole parti e cacciavite
mechanical speed 2 (fast): Small drills and screwing

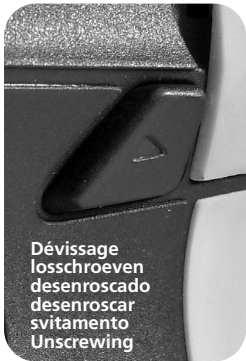

FIG. E

03



Vissage
schroeven
atornillado
enroscando
avvitamento
Screwing



Dévisage
losschroeven
desenroscado
desenroscar
svitamento
Unscrewing

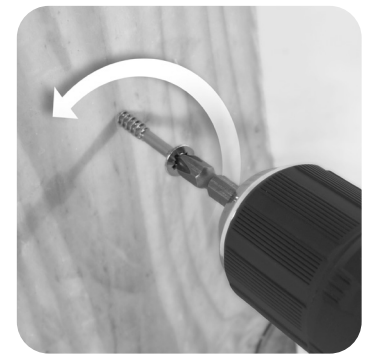

04



Bague de réglage du couple : jusqu'à 58 N.m
Torque instelring: tot 58 N.m
Anillo de ajuste: hasta 58 N.m
Anel de ajuste de torque: até 58 N.m
Ghiera di regolazione: fino a 58 N.m
Torque adjustment ring: up to 58 N.m



Couple maxi : 67 N.m
Max koppel: 67 N.m
Par máximo: 67 N.m
Torque máximo: 67 N.m
Coppia massima: 67 N.m
Maximum torque: 67 N.m



16 réglages de couple pour s'adapter à tous les matériaux, 67 N.m max
16 koppel instellingen voor alle materialen geschikt 67 N.m max
16 pares de torsión que se adaptan a todos los materiales, 67 N.m max
16 ajustes de torque para atender todos os materiais, 67 N.m max
16 valori di coppia in grado di soddisfare tutti i materiali, 67 N.m max
16 torque adjustments for all materials adaptation, 67 N.m max



**FIG. E****05**

Placer le foret ou l'embout de vissage, serrer jusqu'au dé clic : l'outil est serré

Plaats de garde of een schroevendraaier bit, draai totdat deze klikt: De tool is krap
 Coloque la batidora o un destornillador bits, apriete hasta que encaje: La herramienta es apretado
 Coloque o broca ou chave de fenda bit, aperte até encaixá-lo: A ferramenta está apertado
 Posizionare la punta del trapano o un cacciavite po, stringere finché non scatta: Lo strumento è stretto
 Place the drill or screwdriver bit, tighten until it clicks: The tool is tight



Tourner dans le sens inverse, jusqu'au dé clic : l'outil est desserré

Draai in de tegenovergestelde richting totdat het klikt: het gereedschap is vrijgegeven
 Gire en la dirección opuesta hasta que encaje: la herramienta se libera
 Virar na direção oposta até que ele se encaixe: a ferramenta é liberado
 Girare in senso contrario fino a quando non scatta: lo strumento viene rilasciato
 Rotate reverse until it clicks: the tool loosens





FIG. E

06



CLIC !



← **GRIP**



Fonction percussion : perçage dans le béton, la brique, le parpaing.

percussie-functie: boren in beton, baksteen, betonblokken.
la función de percusión: la perforación en hormigón, ladrillo, bloques de hormigón.
função de percussão: perfuração em concreto, tijolo, bloco de concreto.
funzione di percussioni: foratura di cemento, mattoni, blocchi di calcestruzzo.
Impact function: drilling in concrete, brick, cinder block.

Variateur électronique
Elektronische regelaar
electrónica del inversor
electrónica inversor
Variador electrónico
Electronic variable speed

- ① 0-6000 Hit.min⁻¹
- ② 0-22500 Hit.min⁻¹



Indicateur de charge : ceux-ci s'allument dès la mise en marche de la machine
 Laadindicator : degenen die blijken uit het starten van de machine
 Indicador de carga : aquellos que se apartan de la puesta en marcha de la máquina
 Indicador de carga : aqueles que se ligam a partir do início da máquina
 Indicatore di carica quelli che gira dalla partenza della macchina
 Charge indicator : those that turn from the starting of the machine

07

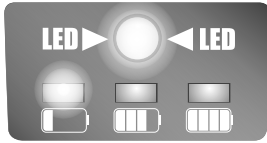

Rechargez votre batterie
 Laad de batterij
 Recargar la batería
 Recarregue a batería
 Ricaricare la batteria
 Recharge your battery

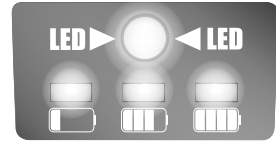
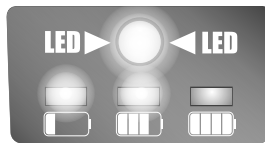

Batterie pleine, machine prête
 opgeladen batterij, het apparaat is klaar
 cargada la batería, la máquina está lista
 batería carregada, o aparelho está pronto
 batteria carica, la macchina è pronta
 charged battery, your machine is ready



Entretien et stockage de la batterie - Verzorging en opslag batterij - Cuidado y almacenamiento de batería - Cuidados e armazenamento da bateria - Cura e conservazione della batteria - Care and Storage Battery



Afin de préserver la durée de vie et performances des batteries, rechargez-les régulièrement (2 mois). La charge d'une batterie diminue naturellement plus ou moins rapidement en fonction de sa technologie. Ne laissez jamais les batteries se décharger complètement suite à une entreposage de longue durée. La technologie lithium-ion implique que la charge de la batterie soit contrôlée par une carte électronique. Ce dispositif bloque toute recharge en cas de décharge profonde des éléments internes de la batterie.

Om de levensduur en de prestaties van de batterijen te sparen, laad ze regelmatig (2 maanden). Het opladen van een batterij zal natuurlijk afnemen meer of minder snel afhankelijk van de technologie. Laat nooit de batterijen volledig ontladen na een langdurige opslag. De lithium-ion-technologie betekent dat de batterij wordt bestuurd door een elektronische kaart. Dit apparaat blokkeert alle laden in geval van een diepe ontlading van de interne elementen van de batterij.

Para preservar la vida y el rendimiento de las baterías, recárguelas regularmente (2 meses). La carga de una batería disminuirá de forma natural, más o menos rápidamente en función de su tecnología. Nunca deje que las baterías se descarguen completamente después de un almacenamiento a largo plazo. La tecnología de litio significa que la batería está controlado por una tarjeta electrónica. Este dispositivo bloquea cualquier recarga en caso de descarga profunda de los elementos internos de la batería.

Para preservar a vida eo desempenho das baterias, carregue-as regularmente (2 meses). O carregamento de uma bateria diminuirá naturalmente mais ou menos rapidamente, dependendo da sua tecnologia. Nunca deixe as baterias descarregar completamente após um armazenamento a longo prazo. A tecnologia de lítio significa que a bateria é controlada por um cartão eletrônico. Este dispositivo bloqueia qualquer recarga no caso de descarga profunda dos elementos internos da bateria.

Per preservare la durata e le prestazioni delle batterie, ricaricare regolarmente (2 mesi). La carica di una batteria tende a ridursi più o meno velocemente a seconda della tecnologia. Non lasciare mai le batterie completamente scarico a seguito di una conservazione a lungo termine. La tecnologia al litio significa che la batteria è controllato da una scheda elettronica. Questo dispositivo blocca qualsiasi ricarica in caso di scarica profonda degli elementi interni della batteria.

To preserve the life and performance of the batteries, charge them regularly (2 months). Charging a battery will naturally decrease more or less quickly depending on its technology. Never let the batteries completely discharge following a long-term storage. The lithium-ion technology means that the battery is controlled by an electronic card. This device blocks any recharge in case of deep discharge of the internal elements of the battery.



13

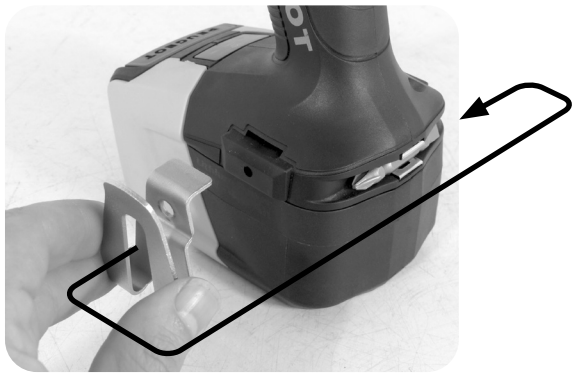

14



Eclairage LED

Luz LED
LED-licht
La luz LED
Alumbrado por LED
LED Lighting

FIG. F

01

Chargeur
Acculader
Cargador de batería
Carregador de batería
Caricabatterie
Battery charger



Batterie
Batterij
Bateria
Bateria
Batteria
Battery



Description et repérage des organes de la machine**FIG. A & B**

- 01 Interrupteur variateur de vitesse
- 02 Inverseur de sens
- 03 Batterie
- 04 Indicateur de charge
- 05 Sélecteur de vitesse mécanique
- 06 Sélecteur de couple
- 07 Mandrin
- 08 Fonction percussion
- 09 Embout de vissage
- 10 Clip ceinture
- 11 -
- 12 -
- 13 Eclairage LED

Contenu du carton**FIG. C****Assemblage de la machine****FIG. D**

- 01 Charger la batterie
- 02 Montage et démontage de la batterie

Fonctionnalité de la machine**FIG. E**

- 01 Mise en marche, réglage de la vitesse
- 02 Utilisation des vitesses mécaniques
- 03 Vissage/dévisage
- 04 Réglage du couple
- 05 Fonction perçage
- 06 Fonction percussion
- 07 Contrôle de la charge de la batterie
- 08 -
- 09 -
- 10 -
- 11 -
- 12 -
- 13 Montage du clip ceinture
- 14 Utilisation de la lumière

Réglages de la machine**FIG. F**

- 01 -
- 02 -

Remplacement des consommables**FIG. G**

- 01 Batterie et chargeur

Entretien, recommandations et conseils

L'utilisation d'accessoires adaptés et en bon état est garant d'un fonctionnement optimal.

Description and location of machine parts**FIG. A & B**

- 01 Speed variator switch
- 02 Reversing device
- 03 Battery
- 04 Charge indicator
- 05 Mechanical speed selector
- 06 Torque selector
- 07 Chuck
- 08 Impact function
- 09 Screw tip
- 10 Belt clip
- 11 -
- 12 -
- 13 LED light

Contents of box**FIG. C****Assembling the machine****FIG. D**

- 01 Charging the battery
- 02 Mounting and removing the battery

Functions of the machine**FIG. E**

- 01 Start-up of the machine, adjusting the speed
- 02 Using the mechanical gears
- 03 Screwdriver
- 04 Adjustment of the torque
- 05 Drilling function
- 06 Impact function
- 07 Checking battery charge
- 08 -
- 09 -
- 10 -
- 11 -
- 12 -
- 13 Use the belt clip
- 14 Use of the light

Settings of the machine**FIG. F**

- 01 -
- 02 -

Replacing consumables**FIG. G**

- 01 Battery and charger

Cleaning and maintenance and advice

The use of suitable accessories in good condition will ensure the machine operates optimally.

Beschrijving en plaatsbepalingen van de onderdelen van de machine

FIG. A & B

- 01 Schakelaar toerenregelaar
- 02 Omkeerschakelaar
- 03 Batterij
- 04 Ladingsmeter
- 05 Mechanische snelheidsschakelaar
- 06 Koppelschakelaar
- 07 Spaninrichting
- 08 Percussiefunctie
- 09 Schroefkop
- 10 Riemclip
- 11 -
- 12 -
- 13 LED verlichting

Inhoud van het karton

FIG. C

Assemblage van de machine

FIG. D

- 01 De batterij opladen
- 02 Montage en demontage van de batterij

Functionaliteit van de machine

FIG. E

- 01 Aanzetten, afstellen van de versnelling
- 02 Gebruik van de mechanische versnellingen
- 03 Vastschroeven/Losschroeven
- 04 Afstelling van het koppel
- 05 Boorfunctie
- 06 Slagfunctie
- 07 Controle van de lading van de batterij
- 08 -
- 09 -
- 10 -
- 11 -
- 12 -
- 13 -
- 14 Gebruik van het licht

Afstellingen van de machine

FIG. F

- 01 -
- 02 -

Vervanging van de accessoires

FIG. G

- 01 Batterij en lader

Onderhoud, aanbevelingen en raadgevingen

Het gebruik van aangepaste accessoires in goede staat waarborgt een optimale werking

Descripción y localización de los elementos de la máquina

FIG. A & B

- 01 Interruptor variador de velocidad
- 02 Inversor de sentido
- 03 Batería
- 04 Indicador de carga
- 05 Selector mecánico de velocidad
- 06 Selector de par
- 07 Mandril
- 08 Función percusión
- 09 Boquilla de atornillado
- 10 Pinza para el cinturón
- 12 -
- 12 -
- 13 Iluminación LED

Contenido del cartón

FIG. C

Ensamblaje de la máquina

FIG. D

- 01 Cambiar la batería
- 02 Montaje y desmontaje de la batería

Funcionalidad de la máquina

FIG. E

- 01 Puesta en marcha, ajuste de la velocidad
- 02 Utilización de las velocidades mecánicas
- 03 Atornillado/desatornillado
- 04 Ajuste del par
- 05 Función taladrado
- 06 Función de percusión
- 07 Control de la carga de la batería
- 08 -
- 09 -
- 10 -
- 11 -
- 12 -
- 13 -
- 14 Utilización de la luz

Ajustes de la máquina

FIG. F

- 01 -
- 02 -

Cambio de los consumibles

FIG. G

- 01 Batería y cargador

Mantenimiento, recomendaciones y consejos

La utilización de accesorios adecuados y en buen estado garantiza un funcionamiento óptimo

Descrizione e localizzazione degli organi della macchina**FIG. A & B**

- 01 Interruttore variatore di velocità
- 02 Invertitore di direzione
- 03 Batteria
- 04 Indicatore di carica
- 05 Selezionatore di velocità meccanico
- 06 Selezionatore di coppia
- 07 Mandrino
- 08 Funzione percussione
- 09 Punta a cacciavite
- 10 Clip da cintura
- 11 -
- 12 -
- 13 Illuminazione a LED

Contenuto della scatola**FIG. C****Assemblaggio della macchina****FIG. D**

- 01 Caricabatteria
- 02 Montaggio e smontaggio della batteria

Funzionalità della macchina**FIG. E**

- 01 Avvio, regolazione della velocità
- 02 Utilizzazione delle velocità meccaniche
- 03 Avvitamento/svitamento
- 04 Regolazione della coppia
- 05 Funzione trapanatura
- 06 Funzione percussione
- 07 Controllo del carico della batteria
- 08 -
- 09 -
- 10 -
- 11 -
- 12 -
- 13 -
- 14 Utilizzazione della luce

Regolazioni della macchina**FIG. F**

- 01 -
- 02 -

Sostituzione dei pezzi di ricambio**FIG. G**

- 01 Batteria e caricatore

Manutenzione, raccomandazioni e consigli

L'utilizzazione di accessori adatti e il buono stato garantiscono un funzionamento ottimale.

Descrição e identificação dos órgãos da máquina**FIG. A & B**

- 01 Interruptor variador de velocidade
- 02 Inversor de sentido
- 03 Bateria
- 04 Indicador de carga
- 05 Selector de velocidade mecânica
- 06 Selector de binário
- 07 Mandril
- 08 Impact function
- 09 Ponta de aperto
- 10 Clipe de cinto
- 11 -
- 12 -
- 13 Iluminação LED

Conteúdo da caixa**FIG. C****Montagem da máquina****FIG. D**

- 01 Carregar a bateria
- 02 Montagem e desmontagem da bateria

Funcionalidade da máquina**FIG. E**

- 01 Accionamento, ajuste da velocidade
- 02 Utilização das velocidades mecânicas
- 03 Aparafusamento/desaparafusamento
- 04 Ajuste do binário
- 05 Função de perfuração
- 06 Função de percussão
- 07 Controlo de carga da bateria
- 08 -
- 09 -
- 10 -
- 11 -
- 12 -
- 13 -
- 14 Utilização da iluminação

Ajustes da máquina**FIG. F**

- 01 -
- 02 -

Substituição de consumíveis**FIG. G**

- 01 Bateria e carregador

Manutenção preventiva, recomendações e conselhos

A utilização de acessórios adaptados e em boas condições é a garantia de um funcionamento ideal



	NIVEAU DE PRESSION ACOUSTIQUE :	82,8 dB (A)
	NIVEAU AKOESTISCHE DRUK :	
	NIVEL DE PRESIÓN ACÚSTICA :	
	NÍVEL DE PRESSÃO ACÚSTICA :	
	LIVELLO DI PRESSIONE ACUSTICA :	
ACOUSTIC PRESSURE LEVEL :		

	NIVEAU DE PUISSANCE ACOUSTIQUE :	93,8 dB (A)
	NIVEAU AKOESTISCH VERMOGEN :	
	NIVEL DE POTENCIA ACÚSTICA :	
	NÍVEL DE POTÊNCIA ACÚSTICA :	
	LIVELLO DI POTENZA ACUSTICA :	
ACOUSTIC POWER LEVEL :		

	NIVEAU DE VIBRATION :	3,230 m / s ²
	TRILLINGSNIVEAU HAND/ARM :	
	NIVEL DE VIBRACIÓN MANO/BRAZO :	
	NÍVEL DE VIBRAÇÃO MÃO/BRAÇO :	10,340 m / s ²
	LIVELLO DI VIBRAZIONE MANO/BRACCIO :	0,636 m / s ²
	HAND/ARM VIBRATION LEVEL :	

NIVEAU SONORE D'EMISSION:**PERCUSSION**

Pression acoustique LpA poste opérateur	82,8 dB
Incertitude	3
Puissance acoustique LWA	93,8 dB
Incertitude	3

VALEURS DÉTERMINÉES SUIVANT LA NORME EN 62841

LES NIVEAUX DE PRESSION ACOUSTIQUE OBTENUS IN SITU DÉPENDENT:

- DES NIVEAUX RÉELS DE LA MACHINE CONSIDÉRÉES, EN PRENANT EN COMPTE LES INCERTITUDES DÉCLARÉES.

- DU LOCAL ET DE L'INSTALLATION DE LA MACHINE. PRÉFÉREZ UNE PIÈCE DONT L'ACOUSTIQUE EST PLUS FEUTRÉE. ÉVITEZ LES PIÈCES VIDE À GRANDE RÉSONNANCE. PLACEZ VOUS AUPRÈS D'UNE FENÊTRE LE CAS ÉCHÉANT.

- DES OUTILS MONTÉS, DES PIÈCES TRAVAILLÉES, DES RÉGLAGES CHOISIS...

VIBRATIONS:

TOTAL DES VALEURS DE VIBRATION (SOMME VECTORIELLE DES TROIS DIRECTIONS) DÉTERMINÉE SELON EN 62841:

a _h	10,340 m/s ²
Incertitude K	1,5 m/s ²

L'AMPLITUDE D'OSCILLATION PEUT ÊTRE UTILISÉE COMME VALEUR DE COMPARAISON D'OUTILS ÉLECTROPORTATIFS. **ATTENTION:** SI L'OUTIL ÉLECTROPORTATIF EST UTILISÉ POUR D'AUTRES APPLICATIONS, AVEC D'AUTRES OUTILS DE TRAVAIL, L'AMPLITUDE D'OSCILLATION PEUT ÊTRE DIFFÉRENTE.

	NIVEAU DE PRESSION ACOUSTIQUE :	69,5 dB (A)
	NIVEAU AKOESTISCHE DRUK :	
	NIVEL DE PRESIÓN ACÚSTICA :	
	NÍVEL DE PRESSÃO ACÚSTICA :	
	LIVELLO DI PRESSIONE ACUSTICA :	
ACOUSTIC PRESSURE LEVEL :		

	NIVEAU DE PUISSANCE ACOUSTIQUE :	80,5 dB (A)
	NIVEAU AKOESTISCH VERMOGEN :	
	NIVEL DE POTENCIA ACÚSTICA :	
	NÍVEL DE POTÊNCIA ACÚSTICA :	
	LIVELLO DI POTENZA ACUSTICA :	
ACOUSTIC POWER LEVEL :		

NIVEAU SONORE D'EMISSION:**A VIDE**

Pression acoustique LpA poste opérateur	69,5 dB
Incertitude	3
Puissance acoustique LWA	80,5 dB
Incertitude	3

VALEURS DÉTERMINÉES SUIVANT LA NORME EN 62841

LES NIVEAUX DE PRESSION ACOUSTIQUE OBTENUS IN SITU DÉPENDENT:

- DES NIVEAUX RÉELS DE LA MACHINE CONSIDÉRÉES, EN PRENANT EN COMPTE LES INCERTITUDES DÉCLARÉES.

- DU LOCAL ET DE L'INSTALLATION DE LA MACHINE. PRÉFÉREZ UNE PIÈCE DONT L'ACOUSTIQUE EST PLUS FEUTRÉE. ÉVITEZ LES PIÈCES VIDE À GRANDE RÉSONNANCE. PLACEZ VOUS AUPRÈS D'UNE FENÊTRE LE CAS ÉCHÉANT.





- DES OUTILS MONTÉS, DES PIÈCES TRAVAILLÉES, DES RÉGLAGES CHOISIS...



EnergyDrill-18VP40N
250317
PSF18P

PERCEUSE À PERCUSSION
SLAGBOORMACHINE BRUSHLESS
TALADRO A PERCUSSION
FURADOR A PERCUSAO
TRAPANO A PERCUSSION
IMPACT DRILL

CLASSE D'ISOLEMENT : 3 ISOLATIE KLASSE : 3 AISLAMIENTO CLASE : 3 ISOLAMENTO CLASSE : 3 ISOLAMENTO CLASSE : 3 INSULATION CLASS : 3	X
--	---

    <p>PORTER DES LUNETTES DE SÉCURITÉ : PORTER UN MASQUE ANTI-POUSSIÈRE : PORTER UNE PROTECTION AUDITIVE : PORTER DES GANTS : SCHUTZBRILLE TRAGEN : STAUBSCHUTZMASKE TRAGEN : GEHÖRSCHUTZ TRAGEN : HANDSCHUHE TRAGEN : DRAAG EEN VEILIGHEIDSBRIL : DRAAG EEN STOFMASKER : DRAAG GEHOORBESCHERMERS : DRAAG HANDSCHOENEN : LLEVAR PUESTAS GAFAS PROTECTORAS : LLEVAR PUESTA UNA CARTEA DE PROTECCIÓN CONTRA EL POLVO : LLEVAR PUESTA UNA PROTECCIÓN AUDITIVA : USAR GUANTES PORTARE DE GLI OCCHIALI DI SICUREZZA : INDOSSARE UNA MASCHERINA ANTI-POLOVERE : PORTARE UNA PROTEZIONE UDITIVA : INDOSSARE I GUANTI : UTILIZAR ÓCULOS DE SEGURANÇA : UTILIZAR UMA MÁSCARA ANTI-POEIRA : UTILIZAR UMA PROTEÇÃO AUDITIVA : USAR LUVAS : WEAR PROTECTIVE EYEWEAR : WEAR A DUST MASK : WEAR HEARING PROTECTIVE EQUIPMENT : WEAR GLOVES :</p>	X
---	---

 <p>COUPLE TENDRE / DYNAMIQUE : DRAAIMOMENT ZACHTE / DYNAMISCH : FUERZA SUAVE / DINÁMICA : CASAL FLEXÍVEL / DINÂMICO : COPPIA MORBIDO / DINAMICO : SOFT / DYNAMIC TORQUE :</p>	67 N.m
--	--------

 <p>COUPLE DUR / INSTANTANÉ : HARD / ONMIDDELLIJKE KOPPEL : FUERZA DURA / INSTANTÁNEA : HARD / TORQUE INSTANTÁNEO : DIFFICILE / COPPIA Istantanea : HARD / INSTANT TORQUE :</p>	58 N.m
--	--------

 <p>CAPACITÉ DANS LE BÉTON : CAPACITEIT IN BETON : CAPACIDAD DE HORMIGÓN : CAPACIDADE EM CONCRETO : CAPACITÀ IN CALCESTRUZZO : CAPACITY IN CONCRETE :</p>	13 mm
--	-------

 <p>CAPACITÉ DANS LE MÉTAL : CAPACITEIT IN DE METAAL : CAPACIDAD EN EL METAL : CAPACIDADE NO METAL : CAPACITÀ NEL METALLO : CAPACITY IN THE METAL :</p>	19 mm
--	-------

 <p>CAPACITÉ DU MANDRIN : CHUCK CAPACITEIT : CAPACIDAD DE CHUCK : CAPACIDADE DE CHUCK : CAPACITÀ CHUCK : CHUCK CAPACITY :</p>	ø 13 mm
--	---------

 <p>VITESSE À VIDE : LEERLAUFDREHZAHL : VELOCIDAD VACÍA : VELOCIDADE NO VÁCUO : VELOCITÀ A VUOTO : NO-LOAD SPEED :</p>	0-400 min ⁻¹ 0-1500 min ⁻¹
---	---

 <p>VITESSE À VIDE : LEERLAUFDREHZAHL : VELOCIDAD VACÍA : VELOCIDADE NO VÁCUO : VELOCITÀ A VUOTO : NO-LOAD SPEED :</p>	0-6000 Hit.min ⁻¹ 0-23500 Hit.min ⁻¹
---	---

 <p>LIRE LES INSTRUCTIONS AVANT USAGE : LEES VOOR HET GEBRUIK DE INSTRUCTIES : LÉASE LAS INSTRUCCIONES ANTES DE USAR : LER AS INSTRUÇÕES ANTES DA UTILIZAÇÃO : LEGGERE LE ISTRUZIONI PRIMA DELL'USO : READ THE INSTRUCTIONS BEFORE USE :</p>	X
---	---

 <p>POIDS : GEWICHT : PESO : PESO : PESO : WEIGHT :</p>	1,238 kg
--	----------

 <p>CONFORMITÉ EUROPÉENNE : VOLDOET AAN DE EG-NORMEN : CUMPLE CON LAS DIRECTIVAS CE : CONFORME ÀS NORMAS CE : CONFORME ALLE NORME CE : CONFORMS TO EC STANDARDS :</p>	X
--	---

 <p>DANGER : GEVAAR : PELIGRO : PERIGO : PERICOLO : DANGER :</p>	X
---	---

 <p>CAPACITÉ DANS LE BOIS : CAPACITEIT IN HOUT : CAPACIDAD EN MADERA : CAPACIDADE NA MADEIRA : CAPACITÀ IN LEGNO : CAPACITY IN WOOD :</p>	38 mm
--	-------



Chargeur
Acculader
Cargador de batería
Carregador de bateria
Caricabatterie
Battery charger

	TENSION ET FRÉQUENCE ASSIGNÉE:	230-240 V - 50/60 Hz
	AANGEWEZEN SPANNING EN FREQUENTIE:	
	TENSIÓN Y FRECUENCIA FIJADA:	
	TENSÃO E FREQUÊNCIA FIXA:	
	TENSIONE E FREQUENZA ASSEGNATA:	
NOMINAL FREQUENCY AND POWER:		

	POIDS :	0,3 kg
	GEWICHT :	
	PESO :	
	PESO :	
	WEIGHT :	

	CLASSE D'ISOLEMENT : 2	X
	ISOLATIE KLASSE : 2	
	AISLAMIENTO CLASE :2	
	ISOLAMENTO CLASSE :2	
	INSULATION CLASS :2	

	USAGE INTÉRIEUR UNIQUEMENT :	X
	ALLEEN VOOR GEBRUIK BINNENSHUIS :	
	SÓLO PARA USO EN INTERIORES :	
	SOMENTE PARA USO INTERNO :	
	SOLO PER USO INTERNO :	
INTERNAL USE ONLY :		

	PUISSANCE ASSIGNÉE:	21,1 VDC 3A 79 W
	LEERLAUFDREHZAHL:	
	POTENCIA FIJADA:	
	POTENZA ASSEGNATA:	
	POTÊNCIA ASSINADA:	
NOMINAL POWER:		

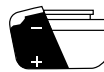

Batterie
Batterij
Batería
Bateria
Batteria
Battery

	TENSION ET FRÉQUENCE ASSIGNÉE:	18 V d.c. 4,0 Ah (Li-Ion)
	AANGEWEZEN SPANNING EN FREQUENTIE:	
	TENSIÓN Y FRECUENCIA FIJADA:	
	TENSÃO E FREQUÊNCIA FIXA:	
	TENSIONE E FREQUENZA ASSEGNATA:	
NOMINAL FREQUENCY AND POWER:		

	POIDS :	0,59 kg
	GEWICHT :	
	PESO :	
	PESO :	
	WEIGHT :	

	NE PAS JETER LES BATTERIES / ACCUMULATEURS AVEC LES ORDURES MÉNAGÈRES	X
	GOOI GEEN BATTERIJEN / ACCU MET HET HUISHOUDELIJK AFVAL	
	NO TIRE LAS PILAS / ACUMULADORES EN LA BASURA DOMÉSTICA	
	NÃO JOGUE PILHAS / ACUMULADORES COM LIXO DOMÉSTICO	
	NON GETTARE LE BATTERIE / ACCUMULATORI CON I RIFIUTI DOMESTICI	
DO NOT DISPOSE OF BATTERIES IN HOUSEHOLD WASTE		

	TEMPS DE CHARGE :	90 min
	OPLAADTIJD:	
	TIEMPO DE CARGA:	
	TEMPO DE CARREGAMENTO:	
	TEMPO DI RICARICA:	
CHARGING TIME :		

	PROTÉGER LA BATTERIE DE TOUTE SOURCE DE CHALEUR (FEU, SOLEIL) RISQUE D'EXPLOSION.	X
	BESCHERM DE BATTERIJ TEGEN HITTE (BRAND, ZON) EXPLOESIE-GEVAAR.	
	PROTEGER LA BATERÍA DE CALOR (FUEGO, SOL) RIESGO DE EXPLOSIÓN.	
	PROTEGER A BATERIA DO CALOR (FOGO, O SOL) RISCO DE EXPLOSAO.	
	PROTEGERE LA BATTERIA DA FONTI DI CALORE (FUOCO, SOLE) IL RISCHIO DI ESPLOSIONE.	
PROTECT THE BATTERY FROM ALL SOURCES OF HEAT (FIRE, SUN) RISK OF EXPLOSION.		

		X





	SOUJIS À RECYCLAGE :	X
	NIET WEGWERPEN :	
	SOTTOPOSTI A RICICLAGGIO :	
	SUJEITOS À RECICLAGEM :	
	SOTTOPOSTI A RICICLAGGIO :	
SUBJECTED TO RECYCLING :		

FR-RECYCLAGE DES DÉCHETS:

LES OUTILS, ACCESSOIRES ET LEUR EMBALLAGES DOIVENT SUIVRE UNE VOIE DE RECYCLAGE ADAPTÉE. CONFORMÉMENT AUX DIRECTIVES EUROPÉENNES 2012/19/UE ET 2006/66/CE, LES COMPOSANTS D'UN PRODUIT DOIVENT ÊTRE SÉPARÉS, COLLECTÉS, RECYCLÉS OU ÉLIMINÉS EN CONFORMITÉ AVEC LES RÉGLEMENTATIONS ENVIRONNEMENTALES EN VIGUEUR. LES APPAREILS, BATTERIES, PILES, HUILES, EMBALLAGES DEVRONT ÊTRE DÉPOSÉS DANS LES SYSTÈMES D'ÉLIMINATION DES DÉCHETS SPÉCIAUX TELS QUE DÉCHETTERIES. RENSEIGNEZ VOUS APRÈS DE VOTRE COMMUNE POUR CONNAÎTRE L'ORGANISME LE PLUS PROCHE À MÊME DE TRAITER OU DE COLLECTER CES DÉCHETS.

NL-AFVAL RECYCLING:

GEREEDSCHAP, ACCESSOIRES EN VERPAKKINGEN MOETEN VOLGEN EEN PAD GESCHIKT IS VOOR RECYCLING. VOLGENS DE EUROPESE RICHTLIJNEN 2012/19/UE EN 2006/66/CE, DE COMPONENTEN VAN EEN PRODUCT MOET WORDEN GESCHIEDEN, VERZAMELD, GERECYCLEERD OF VERWIJDERD IN OVEREENSTEMMING MET DE MILIEUVOORSCHRIFTEN. APPARATEN, BATTERIJEN, OLIE, MOET DE VERPAKJING WORDEN GEDEPONEERD IN DE AFVALVERWERKING AFVAL, ZOALS STORTPLAATSEN. NEEM CONTACT OP MET UW GEMEENTE NAAR DE DICHTSTBIJZIJNDE AGENTSCHAP KUNNEN HERHALEN OF HET VERZAMELEN VAN DEZE AFVALSTOFFEN TE VINDEN.

ES-RECICLADO DE LOS RESIDUOS:

LAS HERRAMIENTAS, LOS ACCESORIOS Y LOS ENVASES TIENEN QUE SEGUIR LA VÍA DE RECICLAJE ADECUADA. EN VIRTUD DE LAS DIRECTIVAS EUROPEAS 2012/19/UE Y 2006/66/CE, LOS COMPONENTES DE UN PRODUCTO DEBEN SEPARARSE, RECOGERSE, RECICLARSE O ELIMINARSE DE ACUERDO CON LAS REGLAMENTACIONES MEDIOAMBIENTALES VIGENTES. LOS APARATOS, BATERÍAS, PILAS, ACEITES, ENVASES DEBERÁN LLEVARSE A LOS CENTROS DE ELIMINACIÓN DE RESIDUOS ESPECIALES TALES COMO LOS ECOPARQUES. PEDIR INFORMACIÓN AL MUNICIPIO PAR CONOCER EL CENTRO MÁS CERCANO APTO PARA RECICLAR O RECOGER DICHOS RESIDUOS.

PT-RECICLAGEM DO LIXO:

AS FERRAMENTAS, ACESSÓRIOS E SUAS EMBALAGENS DEVEM SEGUIR UM CANAL DE RECICLAGEM ADAPTADO. CONFORMEMENTE ÀS DIRETIVAS EUROPEIAS 2012/19/UE E 2006/66/CE, OS COMPONENTES DE UM PRODUTO DEVEM SER SEPARADOS, RECOLHIDOS, RECICLADOS OU ELIMINADOS DE ACORDO COM AS REGULAMENTAÇÕES AMBIENTAIS EM VIGOR. OS APARELHOS, BATERIAS, PILHAS, ÓLEOS E EMBALAGENS DEVERÃO SER DEPOSITADOS NOS SISTEMAS DE ELIMINAÇÃO DE DETRITOS ESPECIAIS, TAIS COMO UNIDADES DE TRIAGEM DE DETRITOS. INFORMAR-SE JUNTO AO SEU CONCELHO MUNICIPAL PARA CONHECER O ÓRGÃO MAIS PRÓXIMO HABILITADO A EVACUAR OU RECOLHER ESTES DETRITOS.

IT-RICICLAGGIO DEI RIFIUTI:

GLI APPARECCHI, I LORO ACCESSORI ED IMBALLAGGI DEVONO ESSERE SOTTOPOSTI AD UN PROCESSO DI RICICLAGGIO APPROPRIATO. IN CONFORMITÀ CON LE DIRETTIVE EUROPEE 2012/19/UE E 2006/66/CE, I COMPONENTI DI UN PRODOTTO DEVONO ESSERE SEPARATI, RACCOLTI, RICICLATI O SMALTITI IN CONFORMITÀ CON LE NORMATIVE AMBIENTALI IN VIGORE. GLI APPARECCHI, LE BATTERIE, LE PILE, GLI OLI, GLI IMBALLAGGI DOVRANNO ESSERE CONFERITI NEI SISTEMI DI SMALTIMENTO DEI RIFIUTI SPECIALI COME LE ISOLE ECOLOGICHE. INFORMARSI PRESSO IL PROPRIO COMUNE PER SAPERE QUAL È L'ENTE PIÙ VICINO IN GRADO DI FARE IL TRATTAMENTO O LA RACCOLTA DIFFERENZIATA DI QUESTI RIFIUTI

EN-WASTE RECYCLING:

THE TOOLS, ACCESSORIES AND THEIR PACKAGING MUST USE AN APPROPRIATE RECYCLING CHANNEL. IN COMPLIANCE WITH EUROPEAN DIRECTIVES 2012/19/UE AND 2006/66/CE, A PRODUCT'S COMPONENTS MUST BE SEPARATED, COLLECTED, RECYCLED OR ELIMINATED IN ACCORDANCE WITH THE ENVIRONMENTAL REGULATIONS IN FORCE. THE APPLIANCE, BATTERIES, OILS AND PACKAGING MUST BE DEPOSITED IN THE SPECIAL WASTE ELIMINATION SYSTEMS SUCH AS THE WASTE COLLECTION CENTRES. ASK YOUR COMMUNE FOR INFORMATION ON THE NEAREST ORGANISATION IN A POSITION TO REPROCESS OR COLLECT THIS WASTE

	RECYCLAGE DES BATTERIES :	X
	RECYCLING BATTERIJ :	
	RECICLAJE DE BATERÍAS :	
	RECICLAGEM DE BATERIAS :	
	RICICLAGGIO DELLE BATTERIE :	
	RECYCLING OF BATTERIES :	

FR-RECYCLAGE DES BATTERIES:

À LA FIN DE LEUR VIE UTILE, SÉPAREZ VOUS DE VOS BATTERIES AVEC PRÉCAUTIONS POUR NOTRE ENVIRONNEMENT. LA BATTERIE CONTIENT DU MATÉRIEL DANGEREUX POUR VOUS ET POUR L'ENVIRONNEMENT. IL DOIT ÊTRE RETIRÉ ET ÉLIMINÉ SÉPARÈMENT DANS UNE INSTALLATION QUI ACCEPTE DES BATTERIES AU LITHIUM-ION.

NL-RECYCLING BATTERIJ:

ÅÅN HET EINDE VAN HUN LEVENSDUUR, GOOI BATTERIJEN MET ZORG VOOR HET MILIEU. DE BATTERIJ BEVAT MATERIAAL DAT IS GEVAARLIJK VOOR U EN HET MILIEU. HET MOET WORDEN VERWIJDERD EN VERNIETIGD AFZONDERLIJK OP EEN FACILITEIT DIE LITHIUM-ION BATTERIJEN ACCEPTEERT.

ES-RECICLAJE DE BATERÍAS:

AL FINAL DE SU VIDA ÚTIL, DESECHE LAS BATERÍAS CON EL DEBIDO CUIDADO DE NUESTRO MEDIO AMBIENTE. LA BATERÍA CONTIENE MATERIAL QUE ES PELIGROSO PARA USTED Y EL MEDIO AMBIENTE. DEBE SER RETIRADO Y ELIMINADO POR SEPARADO EN UNA INSTALACIÓN QUE ACCEPTE BATERÍAS DE IONES DE LITIO.

PT-RECICLAGEM DE BATERIAS:

NO FINAL DA SUA VIDA ÚTIL, DESCARTE AS BATERIAS COM O DEVIDO CUIDADO PARA O NOSSO AMBIENTE. A BATERIA CONTÉM MATERIAL QUE É PERIGOSO PARA VOCÊ E PARA O MEIO AMBIENTE. DEVE SER REMOVIDO E ELIMINADO SEPARADAMENTE NUMA INSTALAÇÃO QUE ACEITE BATERIAS DE IÕES DE LÍTIU.

IT-RICICLAGGIO DELLE BATTERIE:

ALLA FINE DELLA LORO VITA ÚTILE, SMALTIRE LE BATTERIE CON LA DOVUTA ATTENZIONE PER IL NOSTRO AMBIENTE. LA BATTERIA CONTIENE MATERIALE CHE È PERICOLOSO PER VOI E PER L'AMBIENTE. ESSA DEVE ESSERE RIMOSSO E SMALTITO SEPARATAMENTE IN UNA STRUTTURA CHE ACCETTA LE BATTERIE AGLI IONI DI LITIO.

EN-RECYCLING OF BATTERIES:

AT THE END OF THEIR USEFUL LIFE, DISCARD BATTERIES WITH DUE CARE FOR OUR ENVIRONMENT. THE BATTERY CONTAINS MATERIAL WHICH IS HAZARDOUS TO YOU AND THE ENVIRONMENT. IT MUST BE REMOVED AND DISPOSED OF SEPARATELY AT A FACILITY THAT ACCEPTS LITHIUM-ION BATTERIES.





EnergyDrill-18VP4oN

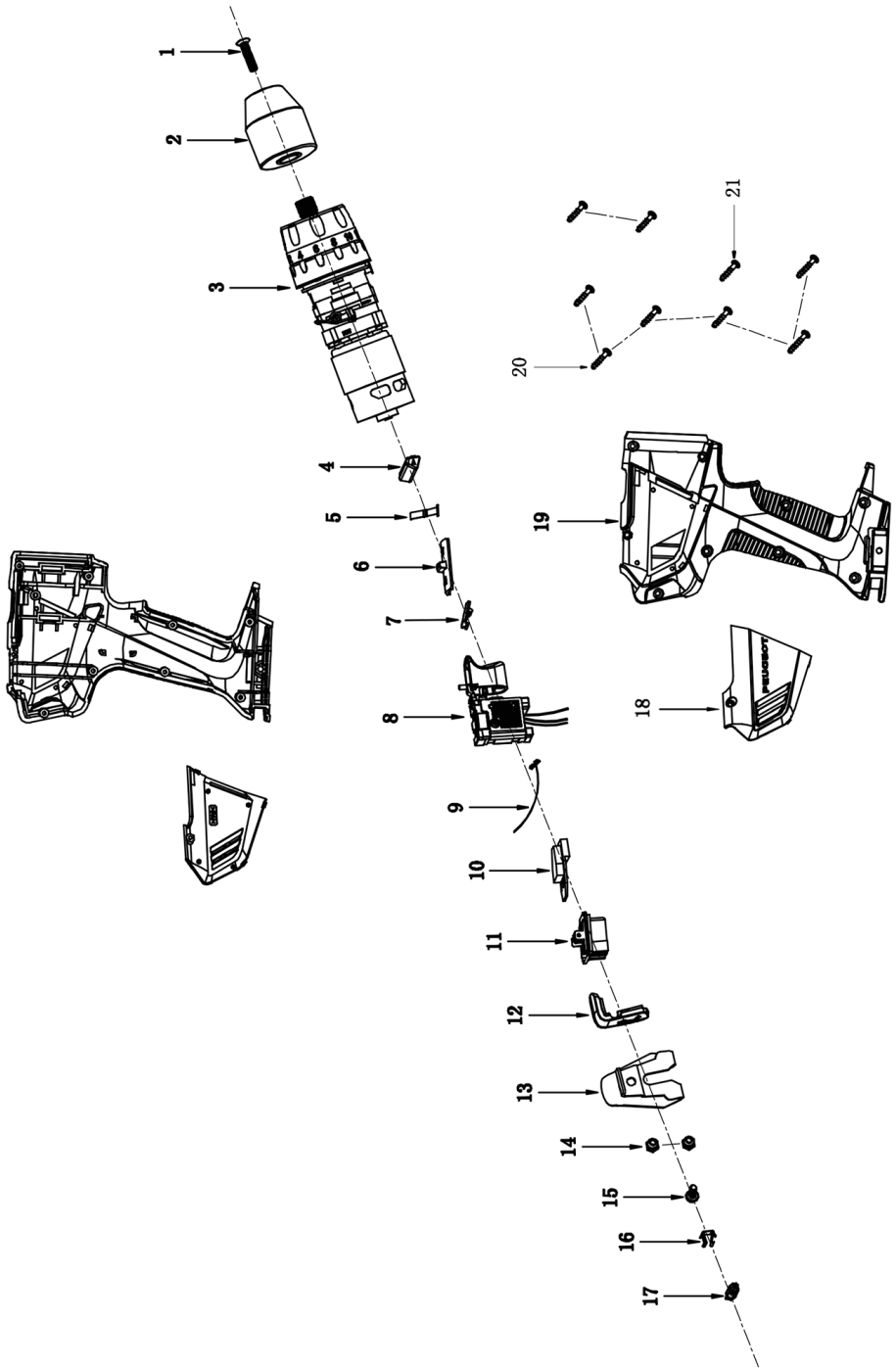

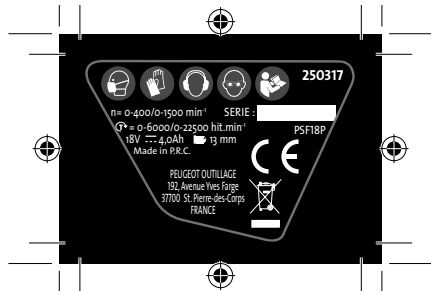

250317-Sticker-C-01-Normes machine.indd 17/05/2021 16:35



250317-Sticker-C-03-Charge batterie.indd 1 17/05/2021 16:35

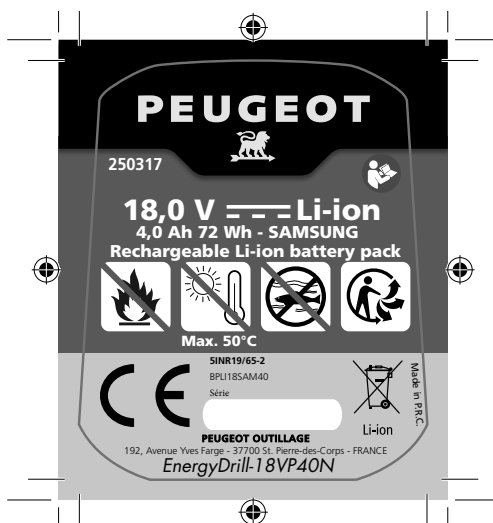

250317-Sticker-C-02-Normes Batterie.indd 1 17/05/2021 16:35

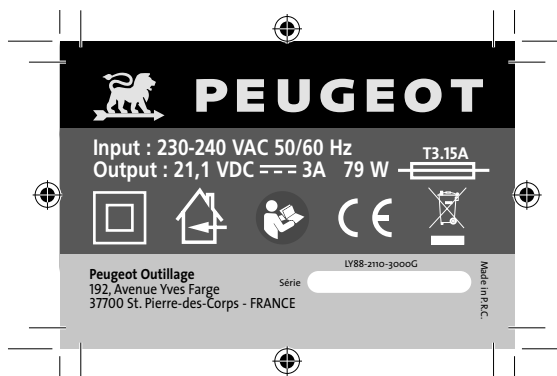

250317-Sticker-C-04-InOut.indd 1 17/05/2021 16:38





PEUGEOT

DECLARATION CE DE CONFORMITE
DECLARACION DE CONFORMIDAD
DICHIARAZIONE DI CONFORMITA

VERKLARING VAN OVEREENSTEMMING
DECLARAÇÃO DE CONFORMIDADE
DECLARATION OF CE CONFORMITY

Le soussigné,
Ondergetekende,
El suscrito,
O abaixo assinado,
Il sottoscritto,
The undersigned,

PEUGEOT OUTILLAGE

192, Avenue Yves Farge - 37700 St. Pierre-des-Corps - FRANCE
Tél. : 02 36 16 71 46 - Fax : 02 36 16 71 40

Déclare par la présente que,
Verklaart hiermede dat,
Declara por la presente, que,
Declara pela presente que,
Dichiare che,
Declares that,

CODE

PEUGEOT / EnergyDrill-18VP40N / 250317 / PSF18P / BPL18SAM40

Perceuse à percussion sans fil / Draadloze percussie boor / Taladro de percusión sin cuerda /
Broca de percussão sem fio / Trapano a percussione cordless / Cordless percussion Drill

Est conforme et satisfait aux normes CE:
In overeenstemming is met en Voldoet aan EG richtlijnen:
Cumple con la directivas de la CE:
Respeita e está em conformidade com as normas CE:
È conforme alle direttive CEE:
Complies with the EEC standards:

MD 2006/42/EC, EMC 2014/30/EU, Rohs 2011/65/UE

Machine : EN55014-1:2006+A1:2009+A2:2011
Machine: EN55014-2:2015
Máquina: EN60745-1:2009+A11:2010
Máquina: EN60745-2-1:2010
Macchina: EN60745-2-2:2010
Machine :
EMC 2014/30/EU LVD 2014/35/EU
Chargeur :
Lader: EN60335-1:2012+A11:2014
Cargador: EN60335-2-29:2004+A2:2010
Carregador: EN62233:2008
Caricabatterie: EN55014-1:2006/+A1:2009/+A2:2011
Charger: EN55014-2:2015
EN61000-3-2:2014
EN61000-3-3:2013

Personne autorisée à
constituer le dossier technique :
Christophe HUREL



SIGMA
Présidente de PEUGEOT OUTILLAGE
Représentée par son Président :
Christophe HUREL
20/12/2018
Fait à St. Pierre-des-Corps



PEUGEOT

BON DE GARANTIE

1 - Objet de la garantie :
La garantie porte exclusivement sur les vices de fabrication ou les vices de matières.
Elle nous oblige à l'échange ou à la réparation des pièces reconnues hors d'usage.

2 - Durée de la garantie :
La garantie est de 36 mois à dater de la livraison du matériel à l'utilisateur (facture ou ticket de caisse à fournir).
Les échanges ou réparations faites au titre de la garantie ne peuvent avoir pour effet de prolonger celle-ci.
Les frais de port ALLER sont à la charge de l'utilisateur.

3 - Réserves :
La garantie ne s'applique en aucun cas aux réparations effectuées en dehors de nos réparateurs agréés.
En aucun cas, durant la période de garantie, le matériel ne devra être démonté.

GARANTIEKAART

1 - Doel van de garantie:
De garantie heeft uitsluitend betrekking op fabricagefouten of gebreken in materialen.
Het dwingt ons om uit te wisselen of reparatie van erkende onbruikbare onderdelen.

2 - Duur van de garantie:
De garantie bedraagt 36 maanden vanaf de levering van apparatuur voor de gebruiker (factuur of kassabon te verstrekken).
De uitwisseling of reparaties onder garantie niet te verlenen.
GO verzendkosten zijn voor rekening van de gebruiker.

3 - Reserves:
De garantie geldt niet in alle reparaties die buiten onze goedgekeurde reparateurs.
In ieder geval gedurende de garantie, moet het materiaal worden verwijderd.

TARJETA DE GARANTÍA

1 - Objeto de la garantía:
La garantía solo se referirán a los defectos de fabricación o defectos en los materiales.
Nos obliga a cambiar o reparación de las piezas fuera de servicio reconocido.

2 - Duración de la garantía:
La garantía es de 36 meses a partir de la entrega de equipos para el usuario (factura o recibo que se den).
Los intercambios o reparaciones bajo garantía no tendrá que prolongarse.
GO gastos de envío correrán a cargo del usuario.

3 - Reservas:
La garantía no se aplica en todas las reparaciones realizadas fuera de nuestros talleres de reparación autorizados.
En cualquier caso, durante el período de garantía, el material debe ser removido.

CARTÃO DE GARANTIA

1 - Finalidade da garantia:
A garantia só relacionar com defeitos de fabricação ou defeitos em materiais.
Ela nos obriga a troca ou reparo de peças inservíveis reconhecidos.

2 - Duração da Garantia:
A garantia é de 36 meses a partir da entrega de equipamentos para o usuário (factura ou recibo a ser fornecido).
Trocas ou reparos sob a garantia não terá que prolongá-la.
GO porte serão custeadas pelo usuário.

3 - Reservas:
A garantia não se aplica a quaisquer reparos feitos fora das nossas oficinas aprovadas.
Em qualquer caso, durante o período de garantia, o material deve ser removido.

GARANZIA

1 - Oggetto della garanzia:
La garanzia si riferisce esclusivamente alla difetti di fabbricazione o difetti nei materiali.
Ci costringe a scambio o la riparazione di parti inutilizzabili riconosciuti.

2 - Durata della garanzia:
La garanzia è di 36 mesi dalla consegna delle attrezzature per l'utente (fattura o ricevuta da fornire).
Scambi o riparazioni in garanzia non sarà necessario prolungarla.
GO spese di spedizione sono a carico dell'utente.

3 - Reserve:
La garanzia non si applica in tutte le riparazioni effettuate al di fuori dei nostri riparatori autorizzati.
In ogni caso, durante il periodo di garanzia, il materiale deve essere rimosso.

WARRANTY

1 - Scope of the warranty :
The warranty shall only apply to manufacturing defects or material defects.
We are obliged to exchange or repair parts that are identified as being unusable

2 - Lifetime warranty :
The warranty shall be valid for 36 months from the delivery date of the equipment to the user (invoice or till receipt must be provided).
Exchanges or repairs carried out under the warranty shall not extend the original warranty period.
The user shall be responsible for original shipping charges.

3 - Reservations :
The warranty shall not under any circumstances cover repairs carried out by a non-authorized repairer.
The equipment should not be dismantled under any circumstances during the warranty period.

DATE D'ACHAT	RÉFÉRENCE MACHINE	CACHET DU DISTRIBUTEUR
DATUM VAN AANKOOP	MACHINE REFERENTIE	DEALER STEMPEL
FECHA DE COMPRA	REFERENCIA DE LA MÁQUINA	COMERCIANTE DE SELLOS
DATA DA COMPRA	REFERÊNCIA DE MÁQUINA	SELO REVENDEDOR
DATA DI ACQUISTO	RIFERIMENTO MACCHINA	TIMBRO DEL RIVENDITORE
PURCHASE DATE	MACHINE CODE	DISTRIBUTOR'S STAMP

SERVICE APRÈS VENTE - AFTER SALE SERVICE

PEUGEOT OUTILLAGE - 192, Avenue Yves Farge - 37700 St. Pierre-des-Corps - FRANCE - Tél. : 02 36 16 71 44 - Fax : 02 36 16 71 40